

BH[®] BH Electronics

HIGH FREQUENCY MAGNETICS

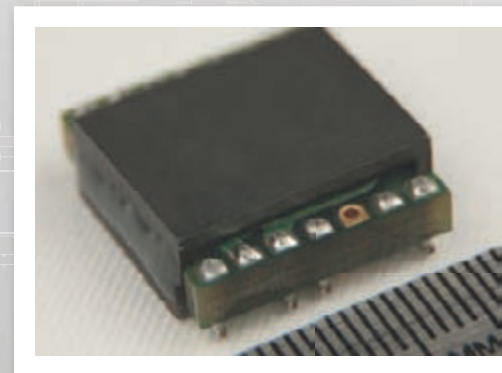

INNOVATIVE MINDS...EXCEPTIONAL QUALITY

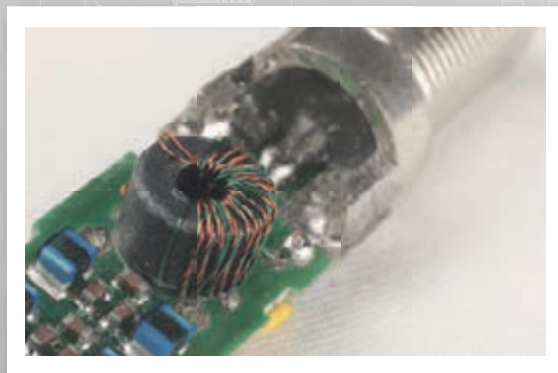

COMPANY OVERVIEW

About BH Electronics 2

Engineering

Manufacturing

Testing & Quality

CUSTOM PRODUCTS

Product Stories 3-5

Ultra-miniature Composite Video Balun

Frequency Domain Multiplex Filter

Low Profile Transformer

CATV Balun

High Operating Temperature Magnetics

Planar Transformer

Precision Tuned Filter Assembly

Ultra-low Capacitance Transformer

Intrinsically Safe Transformer

1: DC-DC POWER PRODUCTS

SMT Dual Inductors/Transformers; CM Chokes 6-18

QTR-Pak® & QTR-PakII® SMT Dual Inductors/1:1 Transformers..... 7-9

8th-Pak™ & 8th-PakII™ SMT Dual Inductors/1:1 Transformers 10-12

Mini-Pak® & Mini-PakII™ SMT Dual Inductors/Transformers 13-15

Comparing QTR-Pak & Mini-Pak Performance..... 16

Variations in Pak Applications 17

Isolated Flyback Transformers..... 18-21

High Temperature (200°C) Transformers/Inductors .. 21

Power and Control Magnetics 22-29

DC-DC Converter Transformers..... 22

Standard Geometries..... 23-25

< 1 Watt..... 23

1 to 25 Watts..... 24

26 to 100 Watts..... 25

Toroid Inductors for Switching Power Supplies..... 26

Current Sense Transformers 27

Control Transformers: MOSFET/TRIAC/SCR Trigger 28

Common Mode Power Chokes 29

2: SIGNAL CONTROL COMPONENTS

For Telecommunications & Data Network Circuits .30-33

Common Mode Chokes for Data & Telecom 30

Baseband Video Components 31

Impedance Matching and Isolation Transformers..... 32-33

3: SPECIALTY PRODUCTS

High Current Power Inductors 34

Extreme Magnetics for Harsh Environments 34-35

4: TEST BALUNS

Network Test Baluns 36

DSL Test Baluns..... 36





BH Electronics

Innovative minds. Exceptional Quality.

BH Electronics is a manufacturer of high frequency devices in the typical range of 20KHz to 1GHz. Our advanced products and capabilities have made us a major player in the High Frequency Magnetics market for nearly 45 years—since 1967. We have developed a series of standard and custom products for some of the world’s leading high-tech companies. Our engineering expertise, precision manufacturing and quality performance make us an industry leader in High Frequency Magnetics.

Our success is built on the pillars of *Engineering, Manufacturing and Quality Assurance.*

ENGINEERING

Our design engineers are highly trained in the technical understanding of High Frequency Magnetics. Our team of skilled professionals is expert in designing magnetic components and has a broad based understanding of end-use applications. We participate in industry standards committees and are fully equipped to meet agency approval requirements.

MANUFACTURING

We employ vertically integrated production capability in our manufacturing process. BH operates a full prototype lab for fast turnaround and precision samples. We produce many of our own molds, jigs and fixtures, keeping cost and manufacturing time at a minimum for our customers. Our Marshall, MN, Mexico and Chinese manufacturing network can handle any level of volume, from just a few parts to many thousands per week.

QUALITY ASSURANCE

Our commitment to quality is proven with our ISO 9001 Quality System, and our decades of experience as a cost effective, high quality magnetics engineering and manufacturing company. From initial customer consultation to design review to high volume manufacture, we follow a rigorous quality process that includes:

- Prototype construction and product approval.
- Process development and approval in the U.S.
- Process approval at the manufacturing location.

Our test equipment is calibrated to NIST standards to ensure consistent results.

BH Electronics specializes in manufacturing:

- Transformers
- Inductors
- Filters
- Standard Magnetics
- Video Components
- Test Baluns
- Specialty Products
- Custom Assemblies
- Devices in the range of 20KHz to 1GHz

Our engineering and technical staff routinely:

- Consults with customers in defining specifications
- Designs complete devices from electrical and mechanical specifications
- Develops package configurations
- Recommends modifications or design alternatives based on manufacturability, enhanced performance, cost-effectiveness and product availability

BH Electronics serves the following markets:

- Telecom/Data Communications
- Medical
- Industrial Control & Instruments
- Military and Aviation
- Security & Video
- Down Hole

Custom Products

ULTRA-MINIATURE COMPOSITE VIDEO BALUN

When the video surveillance industry began changing from coaxial to UTP (Unshielded Twisted Pair) cables for device interconnection, there was a great need to support legacy equipment such as cameras, video switches, distribution hubs and monitors with Category 5 UTP.

BH Electronics responded to this need by developing and manufacturing the L40-0212. Our video balun is a catalog standard balun PC board assembly that is interchangeable between brands by employing unique plastic cases for each customer. The L40-0212 is an ultra-miniature design that allows it to easily fit in crowded rack mounted panels.



FREQUENCY DOMAIN MULTIPLEX FILTER

Digital Subscriber Line (DSL) services available from local telephone companies often require that existing telephone wiring be "multiplexed" to permit telephone and high speed data traffic to share the same wire pair. This requires the development of low cost, high volume passive filter circuits that separate the signals by frequency.

This low-pass filter presents insignificant resistance to signals between DC and 4KHz, but blocks signals from 25KHz to 1.1 MHz. Our low-pass, high-pass and band-pass filters are available for both signal and power applications. Unit volumes from a few parts per month, to many thousand per week are supported.



LOW PROFILE TRANSFORMER

The laws of physics require that a transformer be of a certain minimum size to properly function. This size is often in conflict with the space available on a PC board. Our design team worked together with our customer's engineers to create a Low Profile Transformer. The particular application that led to its creation required a transformer design that was too tall for the assembly into which it was to be placed. Board space was not available to permit a larger footprint. The solution was a part that can be mounted upside down with the magnetic core protruding through a hole in the PC board, thus meeting the overall assembly height requirements.

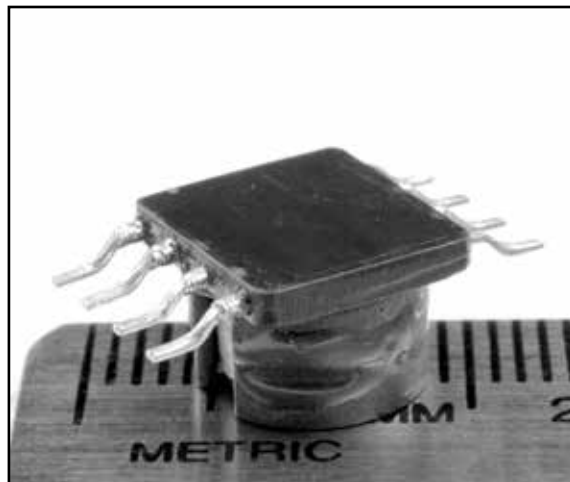

Custom Products Continued

CATV BALUN

Category 5 & 6 unshielded twisted pair cable has steadily become the standard medium for commercial and institutional distribution of Ethernet signals in local area networks. The ready availability of this cable made it a popular choice for delivering several different signals through it, including challenging cable television signals. BH Electronics patented a balun with a 5MHz to 860MHz bandwidth to accommodate the cable signals. The product won the prestigious R&D Magazine 100 Award for being one of the 100 most significant inventions of the year, and was incorporated into Lynx Broadband TV signal distribution products.

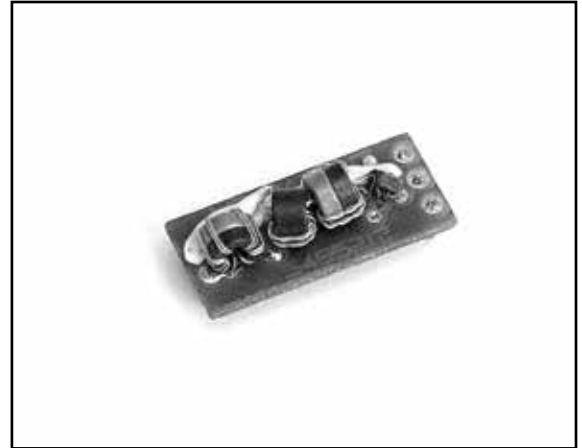

HIGH OPERATING TEMPERATURE MAGNETICS

In order to provide power conversion, power control and communications to the sophisticated, high operating temperature bits used in oil well drills, we have developed inductors and transformers that are designed to operate continuously at temperatures up to 250°C. The pictured components fit inside the drill casing and perform reliably at temperatures of 220°C, providing necessary small diameter packaging and support of power levels up to 100 Watts.



PLANAR TRANSFORMER

The pictured high reliability planar device replaced a low profile wire wound transformer in a high vibration environment. This Planar Transformer was built using multilayer printed circuit board technology. At its heart, this transformer is comprised of an 18 layer printed circuit board with windings etched onto the layers and plated through holes to provide interconnection between layers. This efficient construction technology maximizes space utilization while providing the highest levels of performance and repeatability from part to part, all while withstanding shock, vibration and temperature extremes.

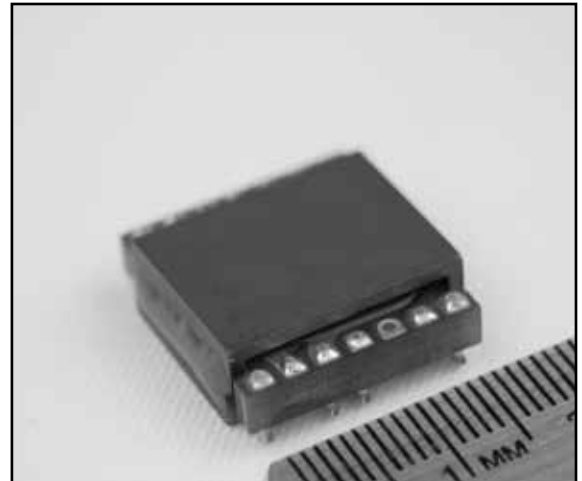

PRECISION TUNED FILTER ASSEMBLY

We developed this precision bandpass filter in three versions to pass frequencies of 250KHz, 500KHz and 2MHz. In each case the tolerance on the passband frequency was only $\pm 0.4\%$. This tight tolerance required that each part be individually tuned to meet the demanding specification.

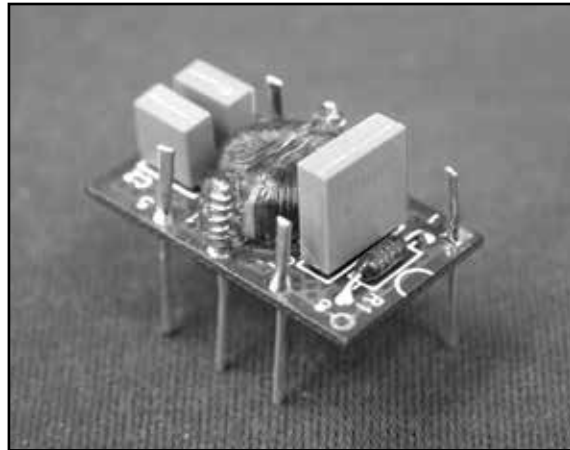

ULTRA-LOW CAPACITANCE TRANSFORMER

Our customers often provide us with difficult specifications for their custom orders. The Ultra-low Capacitance Transformer was one of our most challenging designs, requiring a low level of interwinding capacitance, an extremely low level of noise coupling, high voltage isolation, low physical profile and operation from 200Hz to 6.5KHz. Our designers opted for a dual bobbin transformer, creating an efficient and dependable transformer in the smallest possible size.

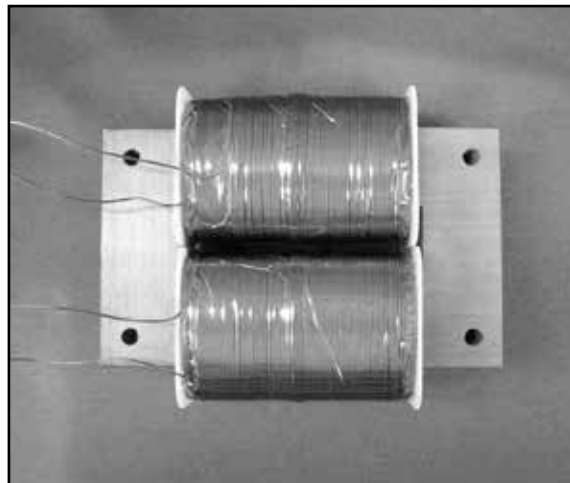

INTRINSICALLY SAFE TRANSFORMER

To create this intrinsically safe transformer with a 6mm minimum distance between its primary and secondary metallic elements, we folded the spacing to maximize the creepage and clearance mandated by safety agencies while keeping the package size as small as possible. The transformer in the image is only 12 x 14 x 12mm. BH Electronics has created several designs that use this technology, mostly for medical applications that require transformer isolation of small electronic devices that are directly connected to patients.

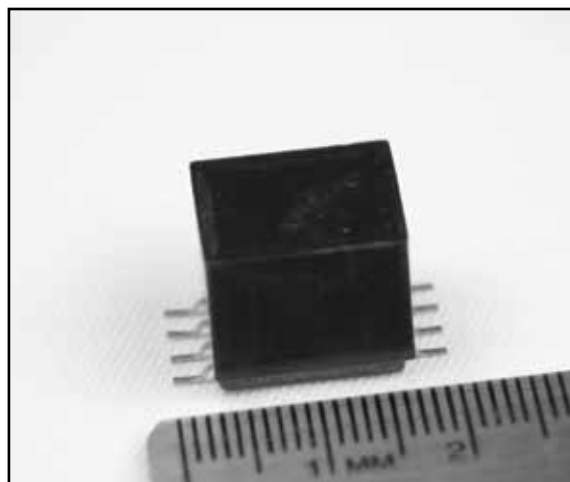

Meet the “Pak” Family – Integrity. Reliability. Inspectability.

All the “Paks” – QTR-Pak™, 8th-Pak™, Mini-Pak™ – have these features:

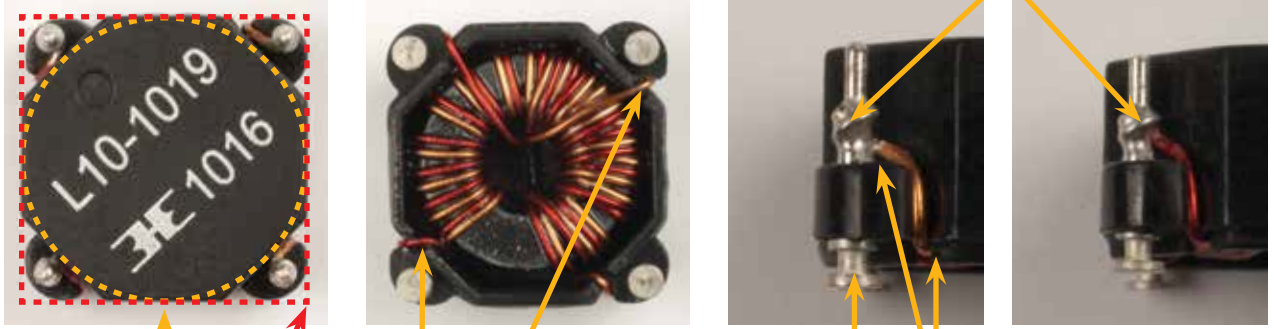

Note integrity of wire-pin bonds

Wire insulation stripped, pre-tinned by hand

Solder will create “flange” over foot

Insulation integrity – no bare copper inside case

Space Efficiency – minimal board area for toroid-based, SMT component

Competitor’s shielded-bobbin, 1:1 design, in contrast:

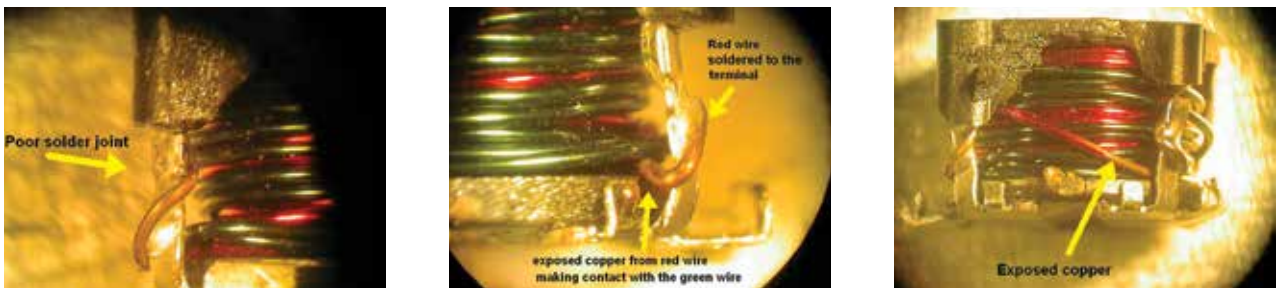

Poor solder joint

Red wire soldered to the terminal

Exposed copper from red wire making contact with the green wire

Exposed copper

Under the “shield”: cold solder joints, bare copper over opposite winding – all hidden from view, results of cheap, automated manufacture. Reliable?

L10/L13 Series SMT Mount Dual Inductors/Transformers

QTR-Pak™ & QTR-Pak II™



High Performance - High Reliability

- High energy storage in high reliability SMT package.
- Low EMI, self-shielding toroid based magnetics.
- Pins: 100% matte Sn over Ni plating over brass.
- Feet available to RoHS reflow temps.
- Dual windings for SEPIC, ZETA and 1:1 transformer circuits.
- Variations quickly available: turns ratios; voltage isolation, etc.

L10 Series: -40 to 125C Operating Range

L13 Series: -40 to 150C Operating Range

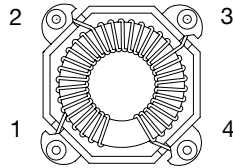
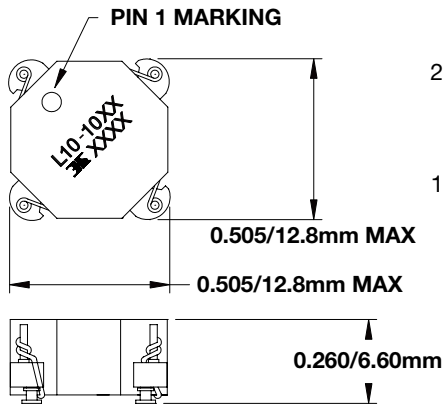
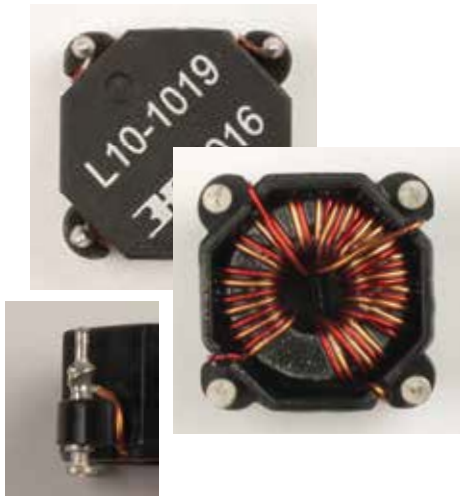

RECOMMENDED PC BOARD LAYOUT

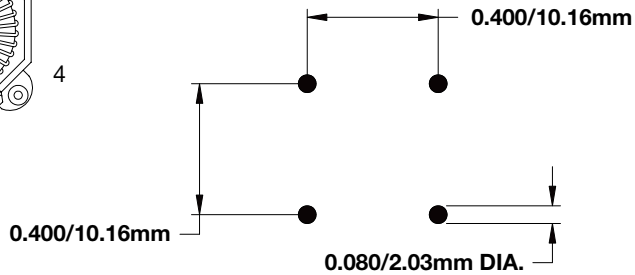

Comparison L10-1022 QTR-Pak vs L13-1020 QTR-Pak II: L (uH) @ I (Adc)

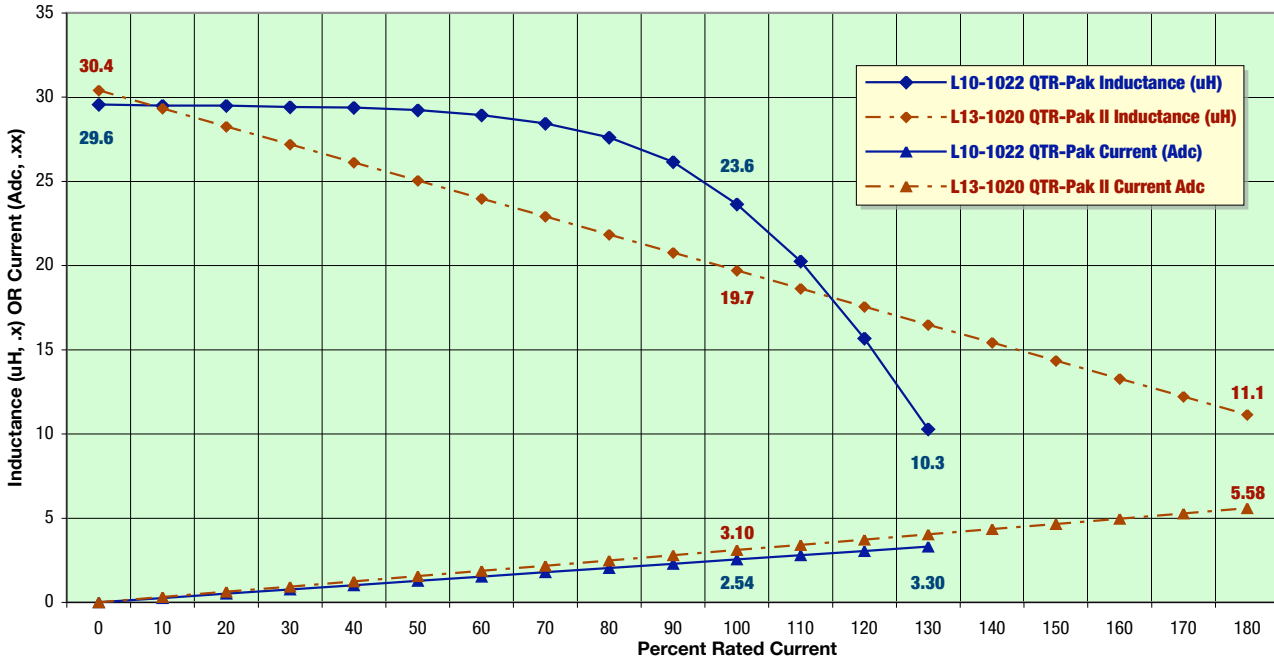

L10-10xx QTR-Pak™

High Reliability, SMT Dual Inductors/1:1 Transformers



RoHS
COMPLIANT

BH Part Number	Parallel				Series			
	Loc (uH) @0ADC	Typical Loc (uH) Biased	Max Current (Adc)	Parallel DCR (Ohms)	Loc (uH) @0ADC	Typical Loc (uH) Biased	Max Current (Adc)	Series DCR (Ohms)
L10-1004	1.36	1.1	11.87	0.004	5.4	4.3	5.94	0.015
L10-1005	1.85	1.5	10.17	0.004	7.4	5.9	5.09	0.018
L10-1006	2.41	1.9	8.90	0.005	9.7	7.7	4.45	0.020
L10-1007	3.05	2.4	7.91	0.007	12.2	9.8	3.96	0.029
L10-1008	3.77	3.0	7.12	0.010	15.1	12.1	3.56	0.040
L10-1009	4.56	3.6	6.47	0.011	18.2	14.6	3.24	0.045
L10-1010	5.43	4.3	5.94	0.012	21.7	17.4	2.97	0.049
L10-1011	6.37	5.1	5.48	0.013	25.5	20.4	2.74	0.053
L10-1012	7.39	5.9	5.09	0.018	29.6	23.6	2.54	0.072
L01-0726	8.48	6.8	4.75	0.019	33.9	27.1	2.37	0.077
L10-1016	12.21	9.8	3.96	0.023	48.9	39.1	1.98	0.092
L10-1017	13.61	10.9	3.75	0.024	54.4	43.6	1.87	0.097
L10-1018	15.08	12.1	3.56	0.041	60.3	48.3	1.78	0.163
L10-1019	18.25	14.6	3.24	0.045	73.0	58.4	1.62	0.180
L10-1020	21.72	17.4	2.97	0.049	86.9	69.5	1.48	0.196
L10-1021	25.49	20.4	2.74	0.066	101.9	81.6	1.37	0.264
L10-1022	29.56	23.6	2.54	0.071	118.2	94.6	1.27	0.284
L10-1023	33.93	27.1	2.37	0.076	135.7	108.6	1.19	0.304
L10-1024	38.60	30.9	2.23	0.104	154.4	123.5	1.11	0.415
L10-1025	43.58	34.9	2.09	0.110	174.3	139.5	1.05	0.441
L10-1026	48.86	39.1	1.98	0.117	195.4	156.3	0.99	0.467
L10-1027	54.44	43.6	1.87	0.155	217.8	174.2	0.94	0.622
L10-1028	60.32	48.3	1.78	0.164	241.3	193.0	0.89	0.654
L10-1029	66.50	53.2	1.70	0.172	266.0	212.8	0.85	0.687
L10-1032	86.86	69.5	1.48	0.243	347.4	278.0	0.74	0.972
L10-1037	126.82	101.5	1.23	0.373	507.3	405.8	0.61	1.491
L10-1038	135.72	108.6	1.19	0.386	542.9	434.3	0.59	1.543
L10-1042	174.32	139.5	1.05	0.437	697.3	557.8	0.52	1.748
L10-1043	184.73	147.8	1.02	0.450	738.9	591.1	0.51	1.800
L10-1044	200.90	160.7	0.98	0.596	803.6	642.9	0.49	2.384
L10-1047	247.35	197.9	0.88	0.661	989.4	791.5	0.44	2.645
L10-1048	272.38	217.9	0.84	0.694	1089.5	871.6	0.42	2.776

1. Parallel DCR = DCR per winding / 2. Series DCR = DCR per winding x 2.
2. Inductance measured at 25° C.
3. Max. current measured at 25° C, 20% inductance roll-off. Above 85° C operating temp., max. current is reduced.
4. Plots of Inductance vs. Current available for all above parts. Contact BH.
5. T&R available: 400 per 13" reel, 1,200 minimum release. Smaller quantities shipped in JEDEC trays.
6. **Highlighted part numbers are standard products. Others are available as non-standard parts with longer lead times.**
7. RoHS parts designated with "L" (e.g., L10-1007). Are electrically the same as non-RoHS designated with "5" (e.g., 510-1007).
8. RoHS "L" and non-RoHS "5" Catalog Parts use pins with matte Sn over Ni barrier over brass. Wire/pin solder is SAC or Sn63/Pb37, respectively.
9. Above parts available with Sn90/Pb10 plated pins on a "custom" part basis. Contact BH for details.

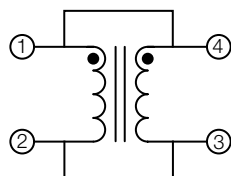

Parallel

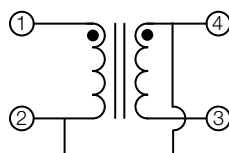

Series

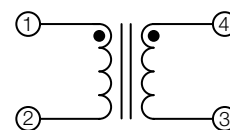

Transformer

L13-10xx QTR-Pak II™ High Temperature (150°C Operating)

High Reliability, SMT Dual Inductors/1:1 Transformers



Part Number	Parallel				Series			
	Loc (uH) @0ADC	Typical Loc (uH) Biased	Max Current (Adc)	Parallel DCR (Ohms)	Loc (uH) @0ADC	Typical Loc (uH) Biased	Max Current (Adc)	Series DCR (Ohms)
L13-1000	1.90	1.24	11.79	0.006	7.60	4.94	5.89	0.024
L13-1001	2.30	1.49	10.72	0.009	9.20	5.98	5.36	0.034
L13-1002	2.74	1.78	9.82	0.009	10.9	7.11	4.91	0.037
L13-1003	3.21	2.09	9.07	0.013	12.8	8.35	4.53	0.051
L13-1004	3.72	2.42	8.42	0.014	14.9	9.68	4.21	0.055
L13-1005	4.28	2.78	7.86	0.015	17.1	11.1	3.93	0.058
L13-1006	4.86	3.16	7.37	0.020	19.5	12.6	3.68	0.079
L13-1007	5.49	3.57	6.93	0.021	22.0	14.3	3.47	0.084
L13-1008	6.16	4.00	6.55	0.022	24.6	16.0	3.27	0.089
L13-1009	6.86	4.46	6.20	0.023	27.4	17.8	3.10	0.094
L13-1010	7.60	4.94	5.89	0.031	30.4	19.8	2.95	0.124
L13-1011	9.20	5.98	5.36	0.034	36.8	23.9	2.68	0.136
L13-1012	10.9	7.11	4.91	0.037	43.8	28.5	2.46	0.149
L13-1014	14.9	9.68	4.21	0.055	59.6	38.7	2.11	0.220
L13-1015	17.1	11.1	3.93	0.073	68.4	44.5	1.96	0.293
L13-1017	22.0	14.3	3.47	0.083	87.9	57.1	1.73	0.333
L13-1018	24.6	16.0	3.27	0.088	98.5	64.0	1.64	0.352
L13-1020	30.4	19.8	2.95	0.125	122	79.0	1.47	0.500
L13-1021	33.5	21.8	2.81	0.131	134	87.1	1.40	0.525
L13-1022	36.8	23.9	2.68	0.137	147	95.6	1.34	0.550
L13-1024	43.8	28.5	2.46	0.189	175	114	1.23	0.757
L13-1025	47.5	30.9	2.36	0.197	190	124	1.18	0.788
L13-1027	63.9	41.5	2.03	0.283	256	166	1.02	1.132
L13-1029	82.8	53.8	1.79	0.322	331	215	0.89	1.288
L13-1031	104	67.6	1.59	0.458	416	271	0.80	1.834
L13-1034	141	91.3	1.37	0.533	562	365	0.69	2.131
L13-1035	154	100	1.31	0.708	616	400	0.65	2.833
L13-1037	182	119	1.20	0.771	730	474	0.60	3.085
L13-1038	198	128	1.16	0.803	791	514	0.58	3.211
L13-1040	230	149	1.07	0.866	920	598	0.54	3.462
L13-1042	265	172	1.00	1.175	1,058	688	0.50	4.701

1. Parallel DCR = DCR per winding / Series DCR = DCR per winding x 2
2. Inductance measured at 25°C.
3. Max. current measured at 25°C. Max. temp and inductance values stable at high temps. Contact us for details.
4. Plots of Inductance vs. Current available for all above parts. Contact BH.
5. T&R available: 400 per 13" reel, 1,200 minimum release. Smaller quantities shipped in JEDEC trays.
6. Cores have been tested at 200°C for 10,000 hours with no harmful effects.
7. For above inductor/transformer values that can operate to 200°C, see Page 23.

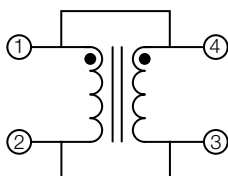

Parallel

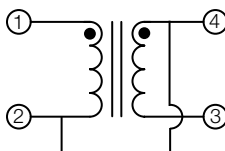

Series

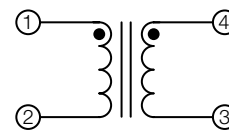

Transformer

L11/L14 Series SMT Dual Inductors/Transformers

8th-Pak™ & 8th-Pak II™



High Performance - High Reliability

- High energy storage in high reliability SMT package.
- Pins: 100% matte Sn over Ni plating over brass.
- Pin / wire solder terminations 100% available to visual inspection.
- Feet available to RoHS reflow temps.
- Dual windings for SEPIC, ZETA and 1:1 transformer circuits.
- Variations quickly available: turns ratios; voltage isolation, etc.

L11 Series: -40 to 125C Operating Range

L14 Series: -40 to 150C Operating Range

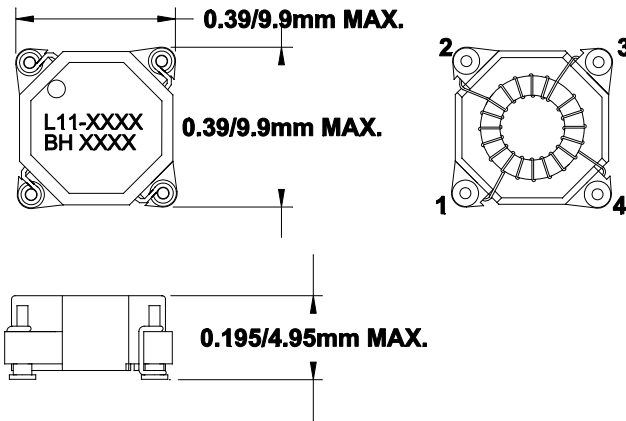

RECOMMENDED PC BOARD LAYOUT

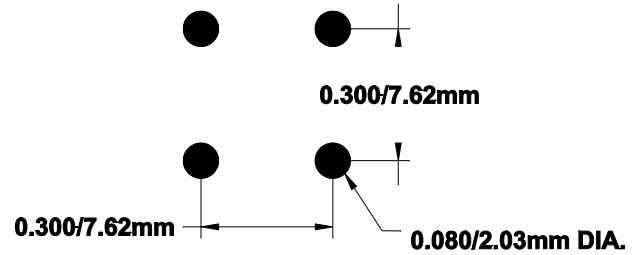

Comparison L11-1014 8th-Pak vs L14-1027 8th-Pak II: L (uH) @ I (A dc)

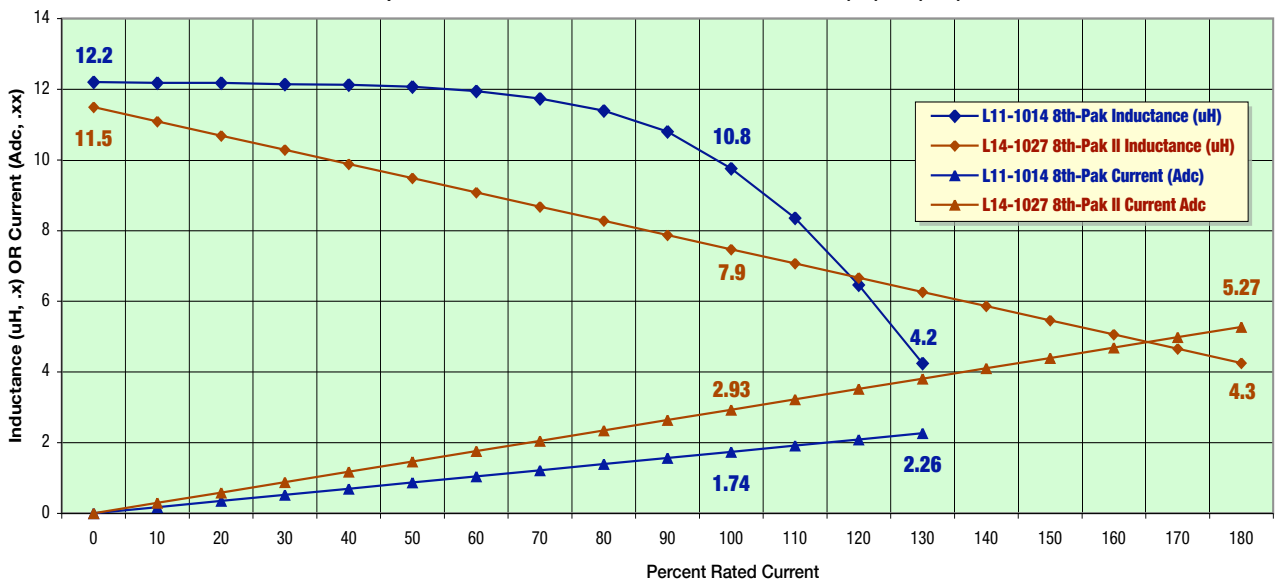

L11-10xx 8th-Pak™ SMT Dual Inductors/1:1 Transformers



RoHS
COMPLIANT

HIGH FREQUENCY POWER PRODUCTS

Part Number	Parallel				Series			
	Loc (uH) @0ADC	Typical Loc (uH) Biased	Max Current (Adc)	Parallel DCR (Ohms)	Loc (uH) @0ADC	Typical Loc (uH) Biased	Max Current (Adc)	Series DCR (Ohms)
L11-1007	0.56	0.45	8.11	0.002	2.2	1.79	4.05	0.007
L11-1008	0.99	0.79	6.08	0.004	4.0	3.17	3.04	0.014
L11-1009	1.55	1.24	4.86	0.006	6.2	4.96	2.43	0.022
L11-1010	2.23	1.79	4.05	0.007	8.9	7.14	2.03	0.027
L11-1110	3.04	2.43	3.47	0.010	12.2	9.72	1.74	0.040
L11-1011	3.97	3.17	3.04	0.014	15.9	12.7	1.52	0.057
L11-0033	5.02	3.76	2.70	0.013	20.1	15.0	1.35	0.050
L11-1012	6.20	4.96	2.43	0.023	24.8	19.8	1.22	0.091
L11-1013	8.93	7.14	2.03	0.034	35.7	28.6	1.01	0.137
L11-1014	12.2	9.72	1.74	0.050	48.6	38.9	0.87	0.198
L11-1015	15.9	12.7	1.52	0.057	63.5	50.8	0.76	0.227
L11-1016	20.1	16.1	1.35	0.064	80.4	64.3	0.68	0.255
L11-1017	24.8	19.8	1.22	0.090	99.2	79.4	0.61	0.360
L11-1018	30.0	24.0	1.11	0.099	120	96.0	0.55	0.396
L11-1019	35.7	28.6	1.01	0.137	143	114	0.51	0.549
L11-1020	41.9	33.5	0.94	0.149	168	134	0.47	0.594
L11-1021	48.6	38.9	0.87	0.160	194	156	0.43	0.640
L11-1022	55.8	44.6	0.81	0.217	223	179	0.41	0.868
L11-1023	63.5	50.8	0.76	0.231	254	203	0.38	0.926
L11-1024	71.7	57.3	0.72	0.246	287	229	0.36	0.984
L11-1025	80.4	64.3	0.68	0.327	321	257	0.34	1.307
L11-1026	89.5	71.6	0.64	0.345	358	286	0.32	1.379
L11-1027	99.2	79.4	0.61	0.363	397	317	0.30	1.452
L11-1028	109	87.5	0.58	0.470	437	350	0.29	1.882
L11-1029	120	96.0	0.55	0.493	480	384	0.28	1.972
L11-1030	131	105	0.53	0.515	525	420	0.26	2.061
L11-1031	143	114	0.51	0.538	571	457	0.25	2.151
L11-1032	155	124	0.49	0.560	620	496	0.24	2.240
L11-1033	168	134	0.47	0.583	671	536	0.23	2.330
L11-1034	181	145	0.45	0.766	723	579	0.23	3.063
L11-1035	194	156	0.43	0.794	778	622	0.22	3.176

1. Parallel DCR = DCR per winding / 2. Series DCR = DCR per winding x 2.
2. Inductance measured at 25° C.
3. Max. current measured at 25° C, 20% inductance roll-off. Above 85° C operating temp., max. current is reduced.
4. Plots of Inductance vs. Current available for all above parts. Contact BH.
5. T&R available: 1,000 per 13" reel. Smaller quantities shipped in JEDEC trays.
6. **Highlighted part numbers are standard products. Others are available as non-standard parts with longer lead times.**
7. RoHS parts designated with "L" (e.g., L10-1007). Are electrically the same as non-RoHS designated with "5" (e.g., 510-1007).
8. RoHS "L" and non-RoHS "5" Catalog Parts use pins with matte Sn over Ni barrier over brass. Wire/pin solder is SAC or Sn63/Pb37, respectively.
9. Above parts available with Sn90/Pb10 plated pins on a "custom" part basis. Contact BH for details.

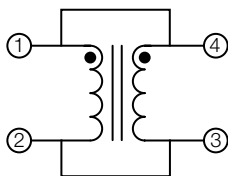

Parallel

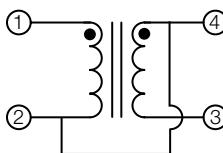

Series

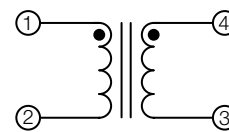

Transformer

L14-10xx 8th-Pak II™ High Temperature (150°C Operating)

High Reliability, SMT Dual Inductors/1:1 Transformers



BH Part Number	Parallel				Series			
	Loc (uH) @0ADC	Typical Loc (uH) Biased	Max Current (Adc)	Parallel DCR (Ohms)	Loc (uH) @0ADC	Typical Loc (uH) Biased	Max Current (Adc)	Series DCR (Ohms)
L14-1010	0.61	0.40	12.70	0.007	2.45	1.59	6.35	0.029
L14-1011	0.83	0.54	10.88	0.011	3.33	2.17	5.44	0.043
L14-1012	1.09	0.71	9.52	0.012	4.35	2.83	4.76	0.049
L14-1013	1.38	0.90	8.46	0.017	5.51	3.58	4.23	0.070
L14-1014	1.70	1.11	7.62	0.019	6.80	4.42	3.81	0.077
L14-1015	2.06	1.34	6.93	0.027	8.23	5.35	3.46	0.108
L14-1016	2.45	1.59	6.35	0.029	9.79	6.36	3.17	0.118
L14-1017	2.87	1.87	5.86	0.040	11.5	7.47	2.93	0.159
L14-1018	3.33	2.17	5.44	0.043	13.3	8.66	2.72	0.171
L14-1019	3.83	2.49	5.08	0.046	15.3	9.95	2.54	0.183
L14-1020	4.35	2.83	4.76	0.062	17.4	11.3	2.38	0.250
L14-1021	4.91	3.19	4.48	0.066	19.7	12.8	2.24	0.265
L14-1022	5.51	3.58	4.23	0.070	22.0	14.3	2.12	0.281
L14-1023	6.14	3.99	4.01	0.074	24.5	16.0	2.00	0.297
L14-1024	6.80	4.42	3.81	0.099	27.2	17.7	1.90	0.394
L14-1025	8.23	5.35	3.46	0.108	32.9	21.4	1.73	0.434
L14-1026	9.79	6.36	3.17	0.146	39.2	25.5	1.59	0.585
L14-1027	11.5	7.47	2.93	0.159	46.0	29.9	1.46	0.634
L14-1029	15.3	9.95	2.54	0.232	61.2	39.8	1.27	0.929
L14-1031	19.7	12.8	2.24	0.263	78.6	51.1	1.12	1.053
L14-1032	22.0	14.3	2.12	0.279	88.1	57.3	1.06	1.115
L14-1033	24.5	16.0	2.00	0.374	98.2	63.8	1.00	1.495
L14-1034	27.2	17.7	1.90	0.393	109	70.7	0.95	1.574
L14-1035	30.0	19.5	1.81	0.413	120	78.0	0.91	1.653
L14-1036	32.9	21.4	1.73	0.433	132	85.6	0.87	1.731
L14-1038	39.2	25.5	1.59	0.598	157	102	0.79	2.390
L14-1039	42.5	27.6	1.52	0.623	170	111	0.76	2.490
L14-1040	46.0	29.9	1.46	0.647	184	120	0.73	2.590
L14-1049	83.3	54.1	1.09	1.350	333	217	0.54	5.398

1. Parallel DCR = DCR per winding / 2. Series DCR = DCR per winding x 2.
2. Inductance measured at 25° C.
3. Max. current measured at 25° C. Max. temp and inductance values stable at high temps. Contact BH for details.
4. Plots of Inductance vs. Current available for all above parts. Contact BH.
5. T&R available: 1,000 per 13" reel. Smaller quantities shipped in JEDEC trays.
- 6. Highlighted part numbers are standard products. Others are available as non-standard parts with longer lead times.**
7. Cores have been tested at 200° C for 10,000 hours with no harmful effects.
8. For above inductor/transformer values that can operate to 200°C, see Page 23.

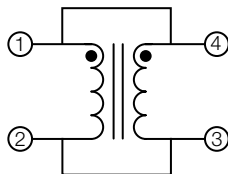

Parallel

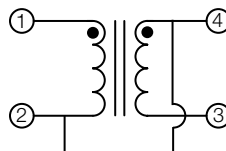

Series

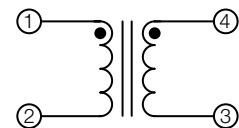

Transformer

L16/L17 Series SMT Dual Inductors/Transformers

Mini-Pak™ & Mini-Pak II™



High Performance - High Reliability

- High energy storage in low profile SMT package (0.150" / 3.81mm).
- Low EMI, self-shielding toroid based magnetics.
- Pins: 100% matte Sn over Ni plating over brass.
- Feet available to RoHS reflow temps.
- Solder-foot bond quality and wetting can be viewed after reflow.

L16 Series: -40 to 125C Operating Range

L17 Series: -40 to 150C Operating Range

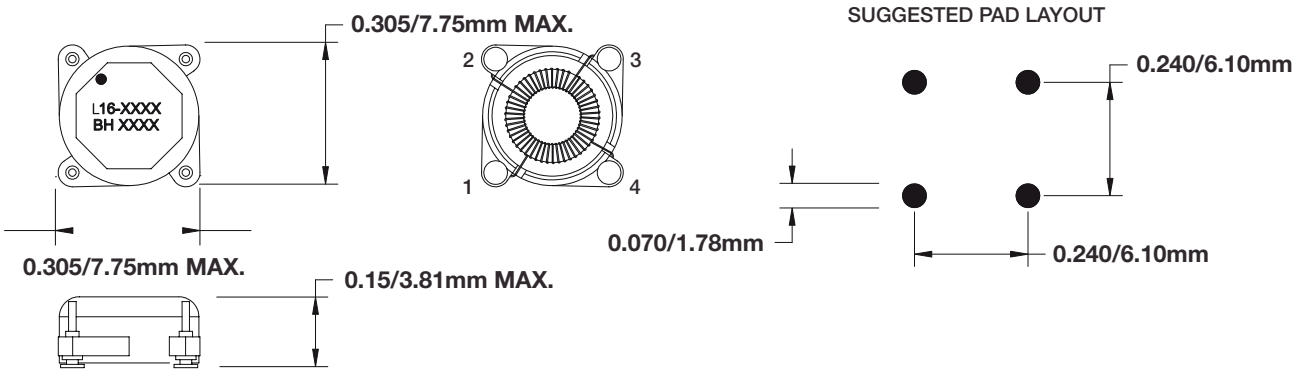

Comparison L16-1013 Mini-Pak vs L17-1013 Mini-Pak II: L (uH) @ I (A dc)

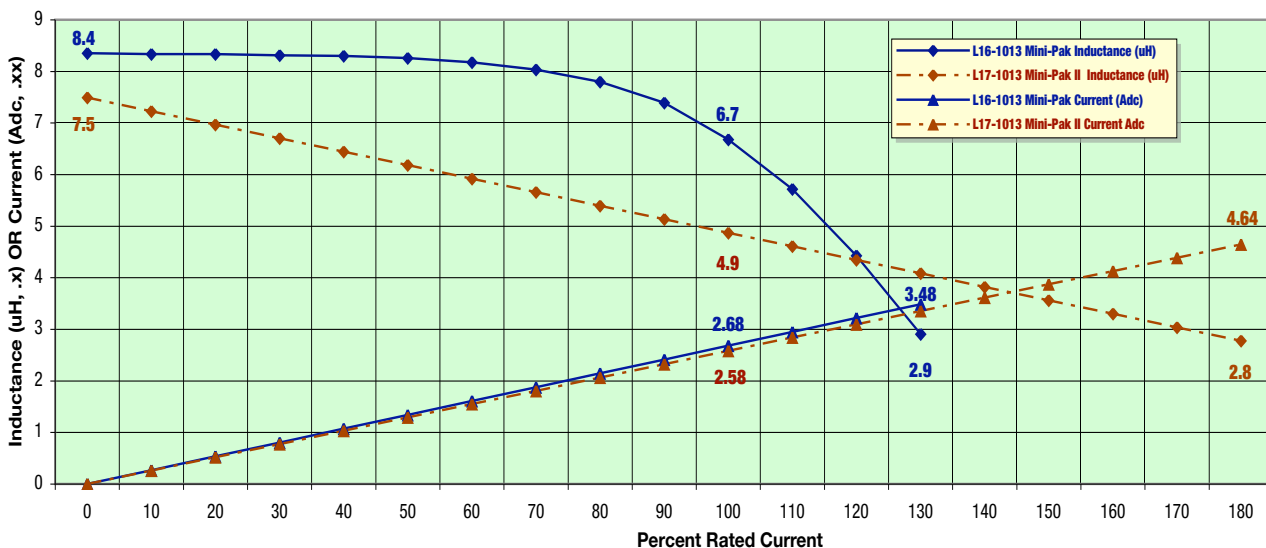

L16-10xx Mini-Pak™

High Reliability, SMT Dual Inductors/1:1 Transformers



BH Part Number	Parallel				Series			
	Loc (uH) @0ADC	Typical Loc (uH) Biased	Max Current	Parallel DCR @20C	Loc (uH) @0ADC	Typical Loc (uH) Biased	Max Current	Series DCR @20C
L16-1000	0.93	0.74	8.03	0.010	3.71	2.97	4.01	0.039
L16-1001	1.17	0.94	7.13	0.011	4.70	3.76	3.57	0.044
L16-1002	1.45	1.16	6.42	0.016	5.80	4.64	3.21	0.062
L16-1003	1.75	1.40	5.84	0.017	7.02	5.61	2.92	0.068
L16-1004	2.09	1.67	5.35	0.024	8.35	6.68	2.68	0.094
L16-1005	2.45	1.96	4.94	0.026	9.80	7.84	2.47	0.102
L16-1006	2.84	2.27	4.59	0.028	11.37	9.09	2.29	0.110
L16-1007	3.26	2.61	4.28	0.036	13.05	10.44	2.14	0.146
L16-1008	3.71	2.97	4.01	0.039	14.85	11.88	2.01	0.156
L16-1009	4.19	3.35	3.78	0.041	16.76	13.41	1.89	0.165
L16-1010	4.70	3.76	3.57	0.056	18.79	15.03	1.78	0.222
L16-1011	5.80	4.64	3.21	0.062	23.20	18.56	1.61	0.247
L16-1012	7.02	5.61	2.92	0.068	28.07	22.46	1.46	0.272
L16-1013	8.35	6.68	2.68	0.094	33.41	26.73	1.34	0.376
L16-1014	9.80	7.84	2.47	0.102	39.21	31.37	1.23	0.408
L16-1015	11.37	9.09	2.29	0.110	45.47	36.38	1.15	0.439
L16-1016	13.05	10.44	2.14	0.149	52.20	41.76	1.07	0.596
L16-1017	14.85	11.88	2.01	0.159	59.39	47.51	1.00	0.635
L16-1018	16.76	13.41	1.89	0.169	67.05	53.64	0.94	0.675
L16-1019	18.79	15.03	1.78	0.224	75.17	60.13	0.89	0.896
L16-1020	20.94	16.75	1.69	0.237	83.75	67.00	0.84	0.946
L16-1022	25.58	20.46	1.53	0.261	102.31	81.85	0.76	1.05
L16-1023	28.07	22.46	1.46	0.338	112.29	89.83	0.73	1.35
L16-1024	30.68	24.55	1.40	0.354	122.73	98.18	0.70	1.41
L16-1027	39.21	31.37	1.23	0.400	156.83	125.47	0.62	1.60
L16-1028	42.28	33.83	1.19	0.525	169.13	135.30	0.59	2.10
L16-1029	45.47	36.38	1.15	0.545	181.89	145.51	0.57	2.18
L16-1030	48.78	39.02	1.11	0.564	195.11	156.09	0.55	2.26
L16-1031	52.20	41.76	1.07	0.584	208.80	167.04	0.54	2.34
L16-1032	55.74	44.59	1.04	0.603	222.95	178.36	0.52	2.41
L16-1033	59.39	47.51	1.00	0.623	237.57	190.05	0.50	2.49

1. Parallel DCR = DCR per winding / 2. Series DCR = DCR per winding x 2.
2. Inductance measured at 25° C.
3. Max. current measured at 25° C, 20% inductance roll-off. Above 85° C operating temp., max. current is reduced.
4. Plots of Inductance vs. Current available for all above parts. Contact BH.
5. T&R available: 1,000 per 13" reel; 250 per 7" reel. Smaller quantities shipped in JEDEC trays.
6. **Highlighted part numbers are standard products. Others are available as non-standard parts with longer lead times.**

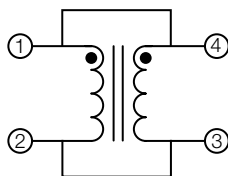

Parallel

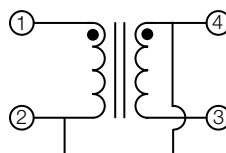

Series

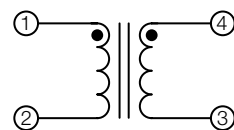

Transformer

L17-10xx Mini-Pak II™ High Temperature (150°C Operating)

High Reliability, SMT Dual Inductors/1:1 Transformers



RoHS
COMPLIANT

BH Part Number	Parallel				Series			
	Loc (uH) @0ADC	Typical Loc (uH) Biased	Max Current	Parallel DCR @20C	Loc (uH) @0ADC	Typical Loc (uH) Biased	Max Current	Series DCR @20C
L17-1000	0.83	0.54	7.74	0.010	3.3	2.2	3.87	0.038
L17-1001	1.05	0.68	6.88	0.011	4.2	2.7	3.44	0.043
L17-1002	1.30	0.85	6.19	0.015	5.2	3.4	3.10	0.061
L17-1003	1.57	1.02	5.63	0.017	6.3	4.1	2.81	0.067
L17-1004	1.87	1.22	5.16	0.023	7.5	4.9	2.58	0.093
L17-1005	2.2	1.43	4.76	0.025	8.8	5.7	2.38	0.100
L17-1006	2.5	1.66	4.42	0.027	10.2	6.6	2.21	0.108
L17-1007	2.9	1.90	4.13	0.036	11.7	7.6	2.06	0.143
L17-1008	3.3	2.2	3.87	0.038	13.3	8.7	1.94	0.153
L17-1009	3.8	2.4	3.64	0.041	15.0	9.8	1.82	0.163
L17-1010	4.2	2.7	3.44	0.055	16.8	11.0	1.72	0.219
L17-1011	5.2	3.4	3.10	0.061	20.8	13.5	1.55	0.243
L17-1012	6.3	4.1	2.81	0.067	25.2	16.4	1.41	0.267
L17-1013	7.5	4.9	2.58	0.093	30.0	19.5	1.29	0.370
L17-1014	8.8	5.7	2.38	0.100	35.2	22.8	1.19	0.401
L17-1015	10.2	6.6	2.21	0.108	40.8	26.5	1.11	0.432
L17-1016	11.7	7.6	2.06	0.146	46.8	30.4	1.03	0.586
L17-1017	13.3	8.7	1.94	0.156	53.2	34.6	0.97	0.625
L17-1018	15.0	9.8	1.82	0.166	60.1	39.1	0.91	0.664
L17-1019	16.8	11.0	1.72	0.220	67.4	43.8	0.86	0.882
L17-1020	18.8	12.2	1.63	0.233	75.1	48.8	0.81	0.931
L17-1021	20.8	13.5	1.55	0.245	83.2	54.1	0.77	0.980
L17-1022	22.9	14.9	1.47	0.257	91.7	59.6	0.74	1.03
L17-1023	25.2	16.4	1.41	0.333	101	65.4	0.70	1.33
L17-1026	32.5	21.1	1.24	0.378	130	84.5	0.62	1.51
L17-1027	35.2	22.8	1.19	0.393	141	91.4	0.60	1.57
L17-1028	37.9	24.6	1.15	0.517	152	98.6	0.57	2.07
L17-1031	46.8	30.4	1.03	0.574	187	122	0.52	2.30
L17-1032	50.0	32.5	1.00	0.593	200	130	0.50	2.37
L17-1033	53.2	34.6	0.97	0.612	213	138	0.48	2.45
L17-1037	67.4	43.8	0.86	0.900	270	175	0.43	3.60
L17-1038	71.2	46.3	0.84	0.925	285	185	0.42	3.70

1. Parallel DCR = DCR per winding / 2. Series DCR = DCR per winding x 2.
2. Inductance measured at 25° C.
3. Max. current measured at 25° C. Max. temp and inductance values stable at high temps. Contact BH for details.
4. Plots of Inductance vs. Current available for all above parts. Contact BH.
5. T&R available: 1,250 per 13" reel, 250 per 7" reel. Smaller quantities shipped in JEDEC trays.
6. Cores have been tested at 200° C for 10,000 hours with no harmful effects.
7. For above inductor/transformer values that can operate to 200°C, see Page 23.

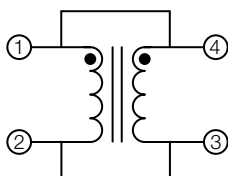

Parallel

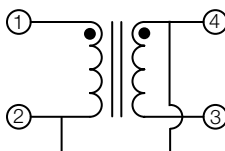

Series

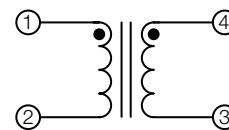

Transformer

L10 vs L16 Series SMT Dual Inductors/Transformers

QTR-Pak™ vs Mini-Pak™



A 15 Year Proven Heritage: High Performance - High Reliability

- Mini-Pak comes with all the qualities of QTR-Pak - in a much smaller package.
- Like QTR-Pak, Mini-Pak has 2 families with different performance features.
- Nearly 50% of QTR-Pak's I @ same L in package requiring 20% the volume (see below).

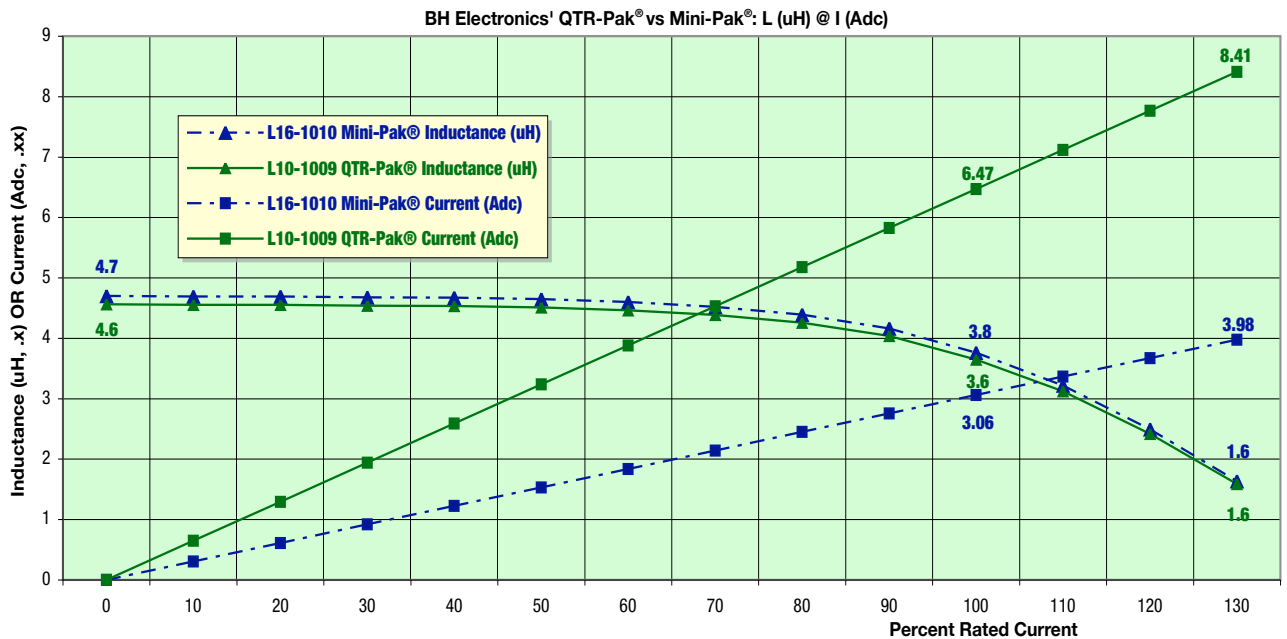
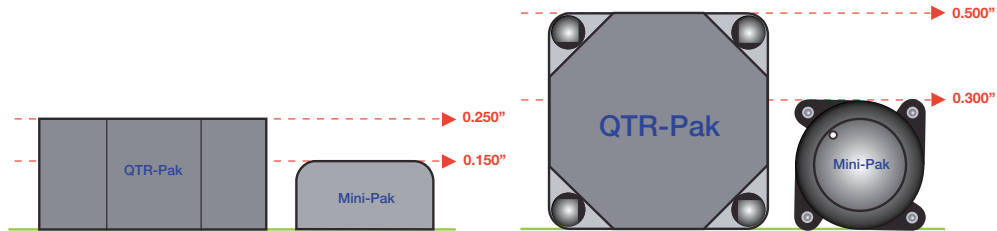

Variations: QTR-Pak™, 8th-Pak™ and Mini-Pak™

Common Threads: SMT; Space Efficiency; Reliability



MIL-PRF-27F, for Level M, Grade 5, Class S

Many standard Pak™ inductors and their variations have been modified on a custom part number basis to meet the following specifications:

Life tests performed for 1,000 hours at 130° C. Thermal shock, mechanical shock and vibration.

Vibration tests that include a 20G peak varied logarithmically between 10-2,000Hz, scanned in ± X, Y and Z directions at 20 minutes per frequency cycle for a total of approximately 12 hours.

QTR-Paks and 8th-Paks have completed tests. Mini-Paks are in process but not yet approved for MIL-PRF-27.

Such tests are possible only because of the SMT structure that is sound in its design: Reliable.

Contact BH with your requirement.

Up to 4,000V isolation

Perhaps you have an application that needs the inductance of one from the standard Pak list of specifications but needs a higher isolation voltage.

We can do that.

Contact BH Electronics.

Turns ratio of 1 to whatever

Standard Pak families are 1:1 transformers / dual inductors but there is no reason this ratio could not be incrementally varied to meet your specific need - quickly and efficiently.

Whether you need a variation on the standard 1:1 ratio for a SEPIC dual inductor or flyback transformer, we can do that for you - quickly and efficiently.

If your 1:1 application could benefit from lower DCR on one side of the circuit than the other - we can do that as well.

Contact BH regarding your specific requirement.

Transformers with different cores?

Would your application benefit from a different core such as Kool-MU® or other?

Contact BH and talk with one of our engineers.

Current Sense Transformers?

See the Current Sense transformers section of this catalog.

Magnetics put into Pak SMT structures provide space efficiency as well as reliability.

Contact BH for a N/C sample.

100/year or 100,000/month?

BH Electronics has the multiple capabilities of small or large volume manufacture.

Whether “custom” or standard, BH is able to quickly respond to your requirement.

If SMT size, performance and reliability are critical to your application - large or small.

Check us out.

Isolated Flyback Transformers

400 to 4,000 VAC

- Range of physical sizes, inductance and current values, turns ratios and isolation voltages.
- Designed for use with many Linear Technology applications.
- Some designed to meet medical isolation and/or intrinsic safety construction requirements.
- Variations of the following examples quickly available from BH Electronics².



BH PART NUMBER	PACKAGE STYLE	SCHE-MATIC	TURNS RATIO	ISOLATION VOLTAGE	LOC (uH)	INDUCTANCE L (uH) at RATED I (ADC)	LEAKAGE L (uH)	DCR PRI (Ohms)	DCR SEC (Ohms)	LINEAR TECH APPS
L16-0017	1	1	1:1	1,500 VAC	13.1	10.4 @ 2.10	0.35	0.76	0.76	LT3663fb
L16-1320	1	1	1:1	1500 VAC	20.9	16.7 @ 1.69	0.5	1.2	1.2	LT3573
L16-1323	1	1	1:1	1,500 VAC	28.1	22.5 @ 1.46	0.37	1.3	1.3	LT3573
L16-1328	1	1	1:1	1,500 VAC	42.3	33.8 @ 1.19	0.4	1.54	1.54	LT3573
L11-1317	2	1	1:1	1,500 VAC	24.8	19.8 @ 1.22	0.95	0.4	0.4	LT3573
L11-0059	2	1	3:1	500 VDC	20.1	16.1 @ 2.50	0.78	0.265	0.026	LT3573
L11-0060	2	1	1:1	1,500 VAC	15.8	12.7 @ 1.52	0.25	0.14	0.14	LT3663fb
L11-0066	2	1	4:1	3,000 VAC	167	139 @ 0.50	3	2.094	0.857	TBD ¹
L11-0067	2	1	4:1	1,500 VAC	230	178 @ 0.41	2.16	1.31	0.15	LT8300
L10-0111	3	1	1:2	1,000 VAC	150	141 @ 1.10	1.29	0.64	2.94	LTM2892
L10-0112	3	1	4:1	1,500 VAC	230	183 @ 0.91	3.38	1.45	0.126	LT8300
L10-0114	3	1	1:4	1,000 VAC	200	160 @ 1.00	1.27	0.96	17.73	LT8300
L10-0115	3	1	4:1	1,500 VAC	500	400 @ 0.70	10	2	0.9	LT8300
L10-0116	3	1	6:1	1,500 VAC	500	400 @ 0.70	7.32	2	0.059	LT8300
L10-0118	3	1	3:1	1,500 VAC	33.9	27.1 @ 2.37	0.65	0.146	0.017	LT3573
L10-1317	3	1	1:1	3,000 VAC	13.6	10.9 @ 4.20	0.25	0.182	0.182	LT3575
L10-1019	3	1	1:1	500 VDC	18.3	14.6 @ 3.20	0.25	0.078	0.078	LT3573
L10-1319	3	1	1:1	3,000 VAC	18.3	14.6 @ 3.20	0.22	0.24	0.24	LT3573
L10-1022	3	1	1:1	500 VDC	29.6	23.6 @ 2.50	0.3	0.118	0.118	LT3574
L10-1322	3	1	1:1	3,000 VAC	29.6	23.6 @ 2.50	0.3	0.266	0.266	LT3574
L10-0108	3	1	3:1	3,000 VAC	27.5	22.0 @ 2.50	1.2	0.15	0.04	LT3573
L10-0110 ²	3	1	1:1	4,000 VAC	24.8	19.8 @ 1.22	0.35	1.76	1.76	LT3574
L00-3126	4	2	1:6	1,600 VAC	80	0.60A	0.38	0.155	9.43	LT3574
L00-3181	5	3	4:1:1:1	1,500 VAC	300	240uH NOM @ 0.50A	2	0.693	0.236	LT3511
L00-3250	7	See Print	1:0.34:0.34	1500 VAC	222	170 @0.50	8.0	1.6	0.64 - 0.45	LT3752EFE, LT8311EFE, DEMO1994A

1. Can be modified to meet UL/IEC 60601-1 medical isolation requirements for creepage and clearance
2. See BH website, www.bhelectronics.com, for latest information on Isolated Flyback Transformers.

SCHEMATICS

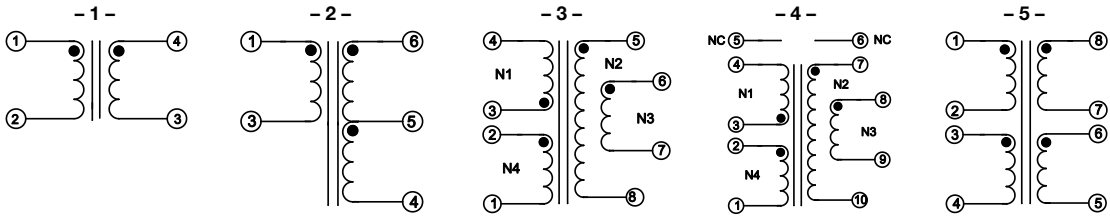

PACKAGE 1

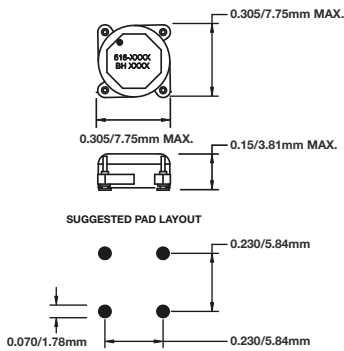

PACKAGE 2

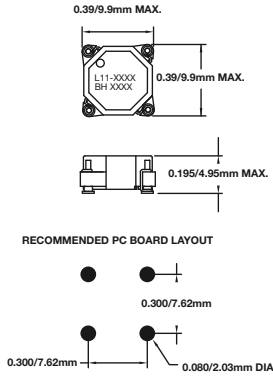

PACKAGE 3

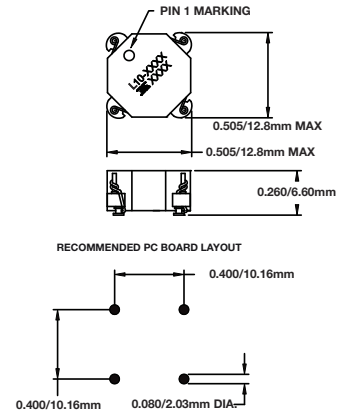

PACKAGE 4

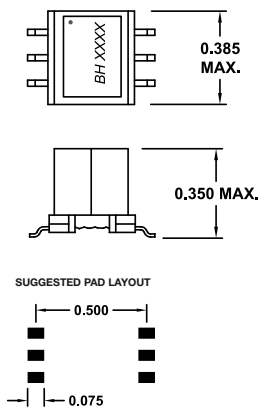

PACKAGE 5

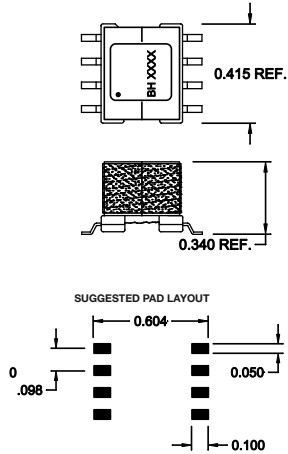

PACKAGE 6

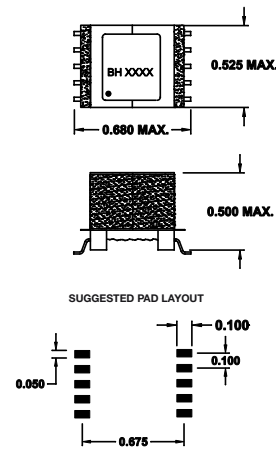

PACKAGE 7

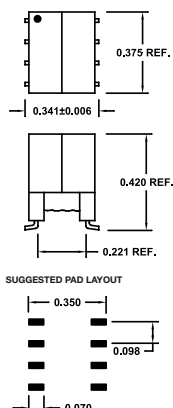

Isolated Flyback Transformer Series

• QTR-Pak – Reference Catalog Page 8

3,000VAC isolated flyback transformers can be made from this family with LOC values of the L10-1004 to L10-1048 on a “quick turn” basis. Part numbers will be listed as L10-13xx for higher isolation versions of the standard L10-10xx QTR-Paks. To compare these parts see the following typical examples:

PART NUMBER	LOC	Isolation	Typ. LOC @ Biased Max Current	DCR (per winding)
L10-1019	18.25	100VDC ¹	14.6uH @ 3.24ADC	.090 Ohms
L10-1319	18.25	1,500VAC ²	14.6uH @ 3.24ADC	.240 Ohms

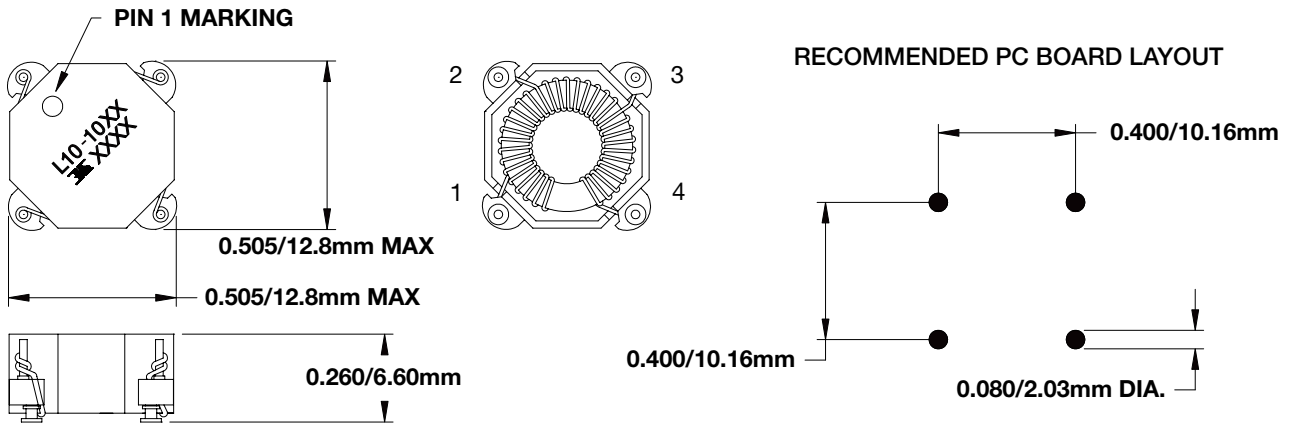

1. Tested to 100VDC; 500VDC NOM.

2. If higher isolation is needed in this structure, contact BH Electronics.

• 8th-Pak – Reference Catalog Page 11

1,500VAC isolated flyback transformers can be made from this family with LOC values of L11-1006 to L11-1027 on a “quick turn” basis. Part numbers will be listed as L11-13xx for higher isolation versions of the standard L11-10xx 8th-Paks. To compare these parts see the following typical examples:

PART NUMBER	LOC	Isolation	Typ. LOC @ Biased Max Current	DCR (per winding)
L11-1017	24.8	100VDC ¹	19.8uH @ 1.22ADC	.180 Ohms
L11-1317	24.8	1,500VAC ²	19.8uH @ 1.22ADC	.400 Ohms

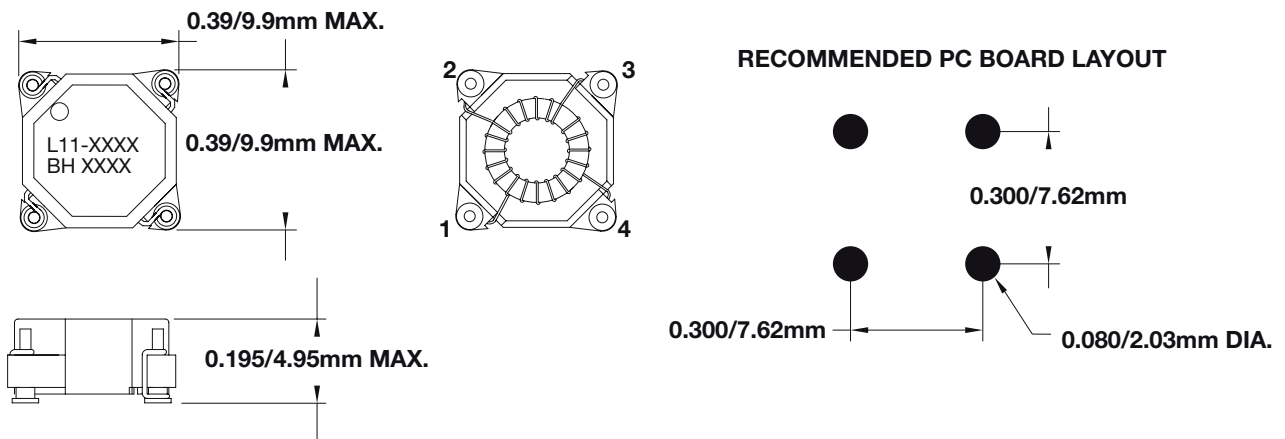

1. Tested to 100VDC, 400VAC NOM.

2. If higher isolation is needed in this structure, contact BH Electronics.

- **Mini-Pak – Reference Catalog Page 14**

1,500VAC isolated flyback transformers can be made from this family with LOC values of L16-1000 to L16-1028 on a “quick turn” basis. Part numbers will be listed as L16-13xx for higher isolation versions of standard L16-10xx Mini-Paks. To compare these parts see the following typical examples:

PART NUMBER	LOC	Isolation	Typ. LOC @ Biased Max Current	DCR (per winding)
L16-1023	28.1	100VDC ¹	22.5uH @ 1.46ADC	.676 Ohms
L16-1323	28.1	1,500VAC ²	22.5uH @ 1.46ADC	1.300 Ohms

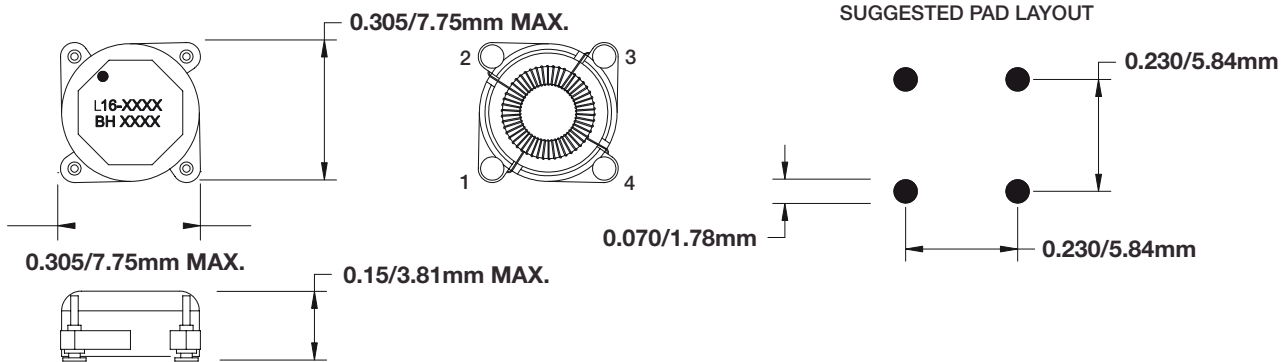

1. Tested to 100VDC, 400VAC NOM.
2. If higher isolation is needed in this structure, contact BH Electronics.

- **UL/IEC Isolation Transformers or other structures**

BH Electronics is a specialist in the design and manufacture of isolation transformers compliant with Agency Specifications including UL / IEC 60601-1 and UL 2601 (Medical), UL / IEC 61010-1 (Laboratory Equipment), UL / IEC 60950 and UL 1950 (Information Technology). Contact BH Electronics to discuss your application.

200°C Transformers / Inductors

- **200°C Transformers in QTR-Pak, 8th-Pak and Mini-Pak structures:**

Any of the transformers / dual inductors listed on Catalog Pages 9 (L13-10xx), Page 12 (L14-10xx) and Page 14 (L17-10xx) can be manufactured by BH to operate at 200C maximum temperature including ambient plus temperature rise. Like the preceding isolation transformers, samples are available on a “quick turn” basis.

Note: All 200°C parts contain lead. Part #L13-1012 (e.g., shown below) will become 513-1012.

To see how their *relative* performance compares based on three “Pak” cases, consider:

SIZE	PART NUMBER	LOC	Typ. LOC @ Biased Max Current	DCR (per winding)
QTR-Pak	L13-1012	10.9	7.11uH @ 5.36ADC	.074 Ohms
8th-Pak	L14-1026	9.79	6.36uH @ 3.17ADC	.292 Ohms
Mini-Pak	L17-1015	10.2	6.6uH @ 2.21ADC	.216 Ohms

Power and Control Magnetics

DC-DC Converter Transformers

- Intended for power isolation such as data line driver circuits
- Designed for use with listed chips and chipsets
- Custom designs available in a wide wattage range with Standard Geometries.



ELECTRICAL CHARACTERISTICS @ 25° C

BH PART NUMBER	TURNS RATIO	ISOLATION VOLTAGE	ET-V μ SEC	SCHEMATIC	PACKAGE STYLE	NOTES	FOR USE W/MAXIM CHIP SET		
							250/251	253	845
500-1635						(Replaced by 500-2580)	•		
L00-1636	1CT:1	1800	30	4	BH009	(formerly Q6471-2)	•		
L00-1658	1CT:1	3750	34	4	BH009		•		
UL L00-1749 ¹	1CT:1CT	4000	30	1A	BH010	5V in to 5 or 10V out	•		
500-1944	1CT:1CT	2000	30	1	BH001	5V in to 5 or 10V out	•		
L00-2015	1CT:1.3CT	1500	18	1	BH008	5V in to 5V out @ 100mA		•	
500-2017	1CT:2.1CT	1500	18	1	BH008	3.3V in to 5V out @ 50mA		•	•
500-2019	1CT:5CT	1500	18	1	BH008	5V in to 24V out @ 10mA		•	•
L00-2045	1CT:1.3CT	500	18	1	BH008	5V in to 5V out @ 200mA		•	•
L00-2047	1CT:2.1CT	500	18	1	BH008	3.3V in to 5V out @ 100mA		•	•
500-2049	1CT:5CT	500	18	1	BH008	5V in to 24V out @ 6mA			
L00-2195	1CT:1.3CT	3750	18	1	See Print	5V in to 5V out @80mA		•	•
UL L00-2327 ¹	1CT:1.3CT	3000	30	1A	BH004	5V in to 5V out @80mA		•	•
UL L00-2345 ¹	1CT:1.25CT	4000	18	6	BH007			•	•
500-2451	1CT:1.3CT	3750	18	1	BH008 ²	5V in to 5V out @80mA		•	•
500-2580	1CT:1	2000	100	5	BH011		•		
500-2582	1:1:1.3	2000	100	5	BH011			•	
L00-2583	1CT:1.3CT	2000	30	1	BH001			•	

Note: Part numbers beginning with "L" are RoHS compliant. (1) UL Recognized component. (2) 0.275 max. height.

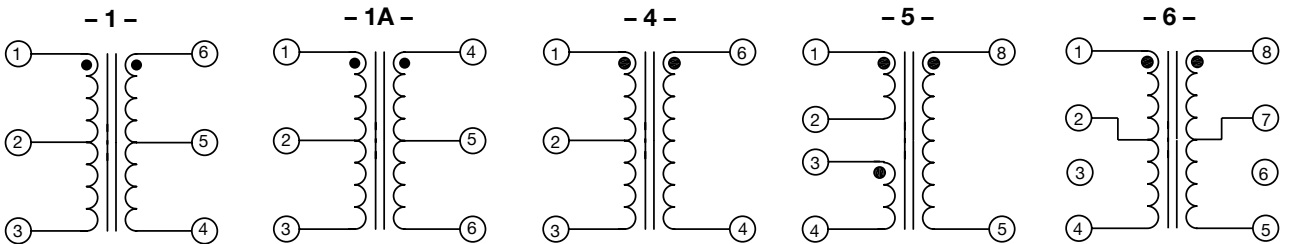

STANDARD GEOMETRIES

See Pages 23-25 for Standard Geometries in ranges from < 1 watt up to 100 watts.



Power and Control Magnetics

DC-DC Converter Transformers

STANDARD GEOMETRIES: <1 WATT

• BH Electronics has a wide range of Standard Geometries to choose from. See below for designs in the <1 watt power range. • Physical size is directly related to frequency of operation and voltage isolation. • Consult BH engineering for your specific application.

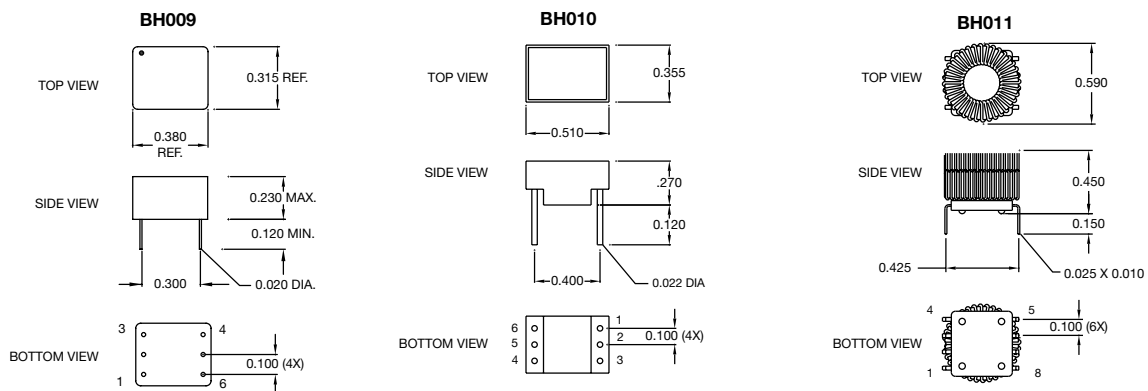
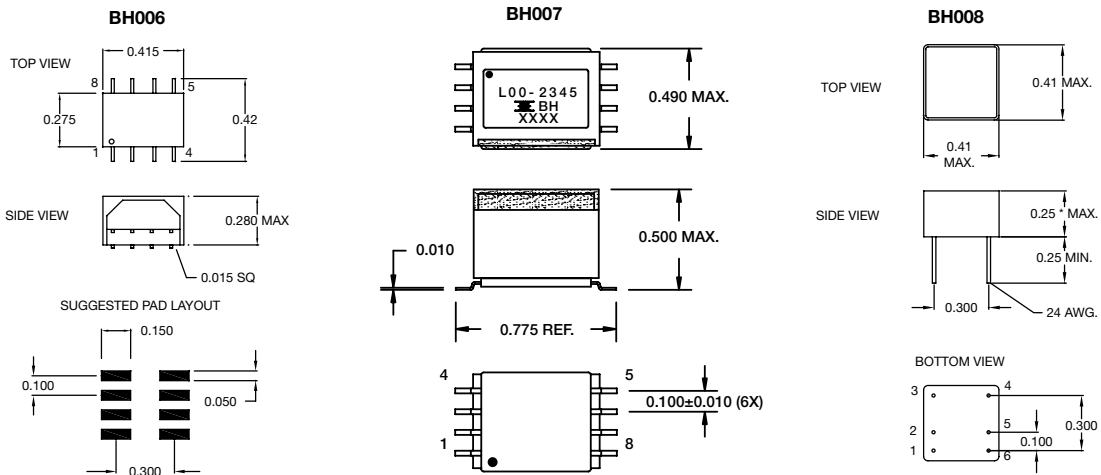
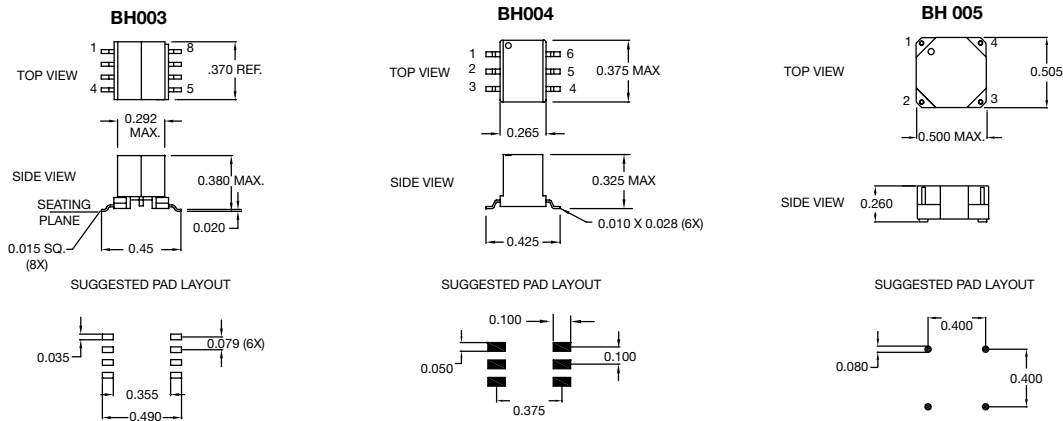
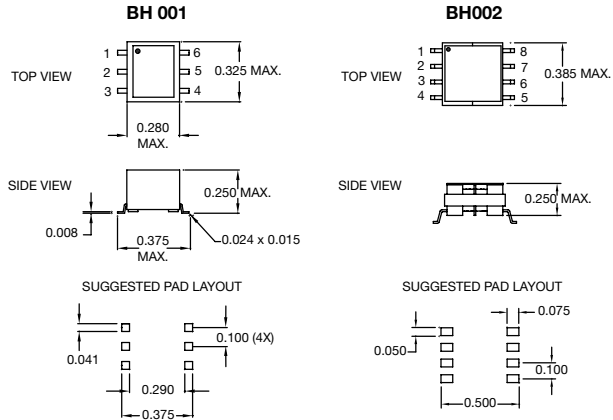

Power and Control Magnetics

DC-DC Converter Transformers

STANDARD GEOMETRIES: 1 TO 25 WATTS

- BH Electronics has a wide range of Standard Geometries to choose from. See below for designs in the 1 to 25 watt power range.
- Physical size is an inverse relationship to frequency but a direct relationship to voltage isolation.
- Consult BH engineering for your specific application.

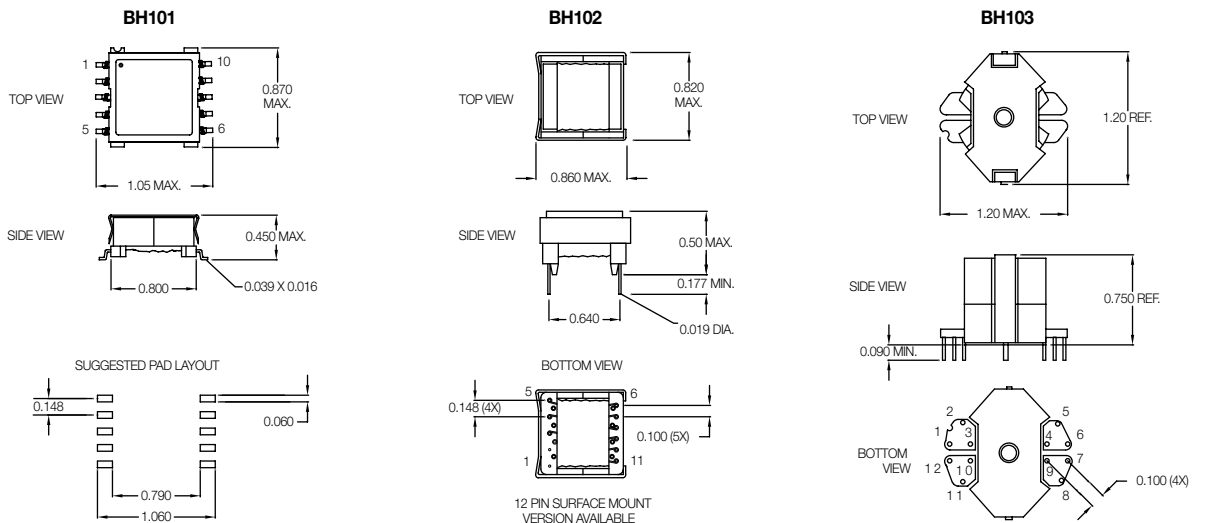
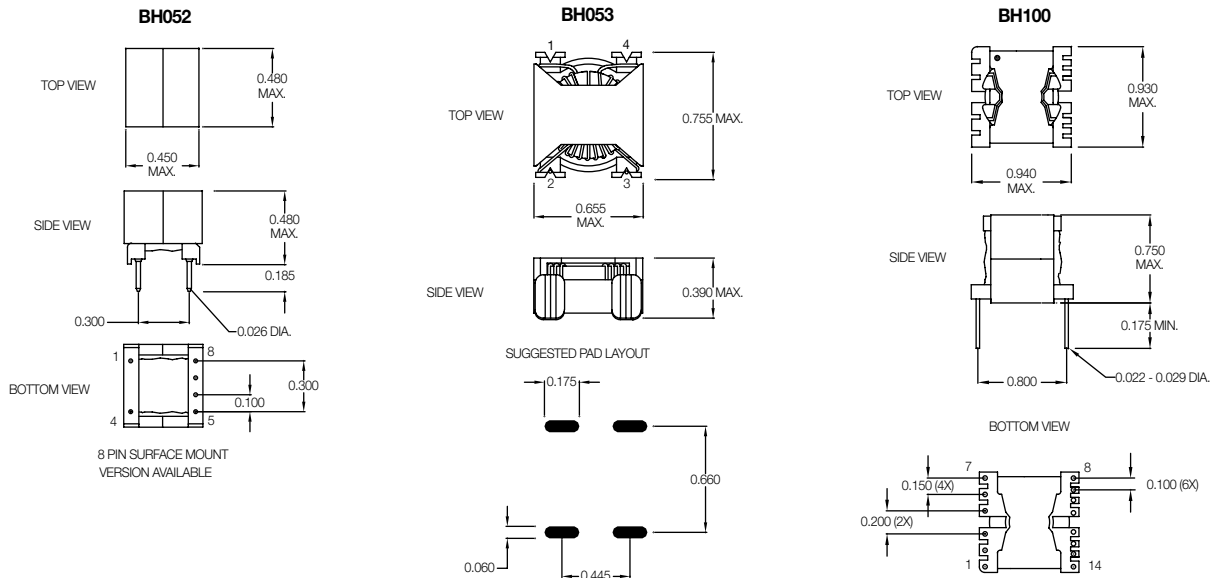
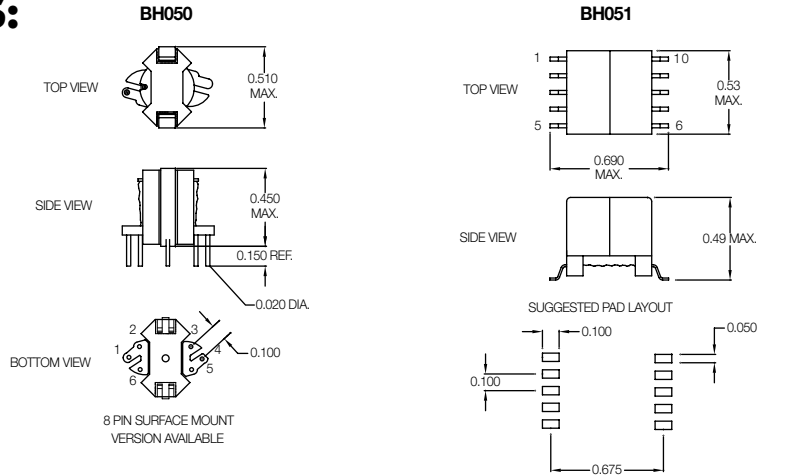

Power and Control Magnetics

DC-DC Converter Transformers

STANDARD GEOMETRIES: 26 TO 100 WATTS

- BH Electronics has a wide range of Standard Geometries to choose from. See below for designs in the 26 to 100 watt power range.
- Physical size is directly related to frequency of operation and voltage isolation.
- Consult BH engineering for your specific application.

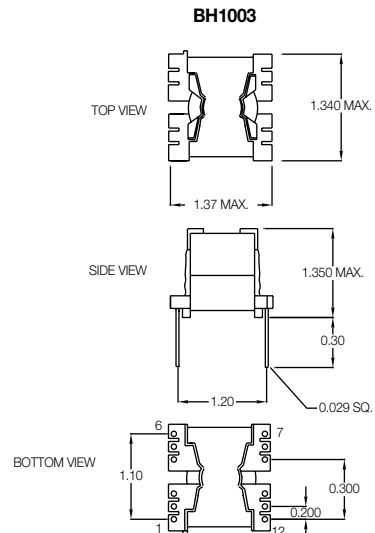
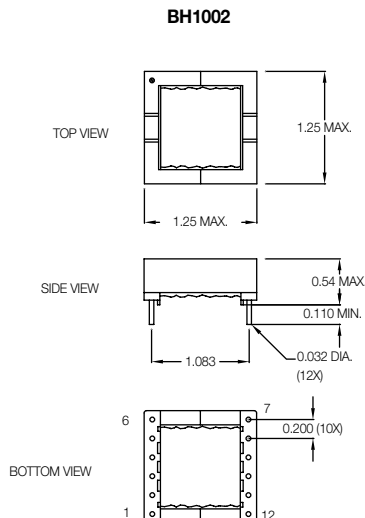
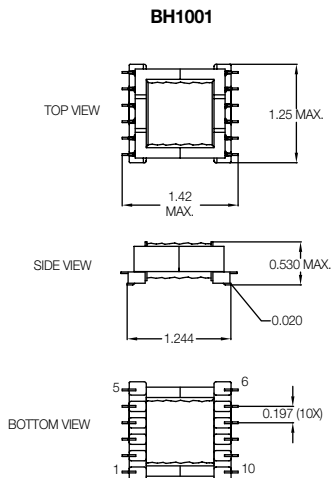
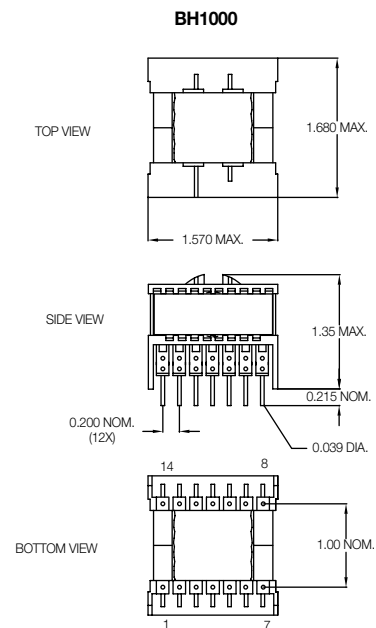
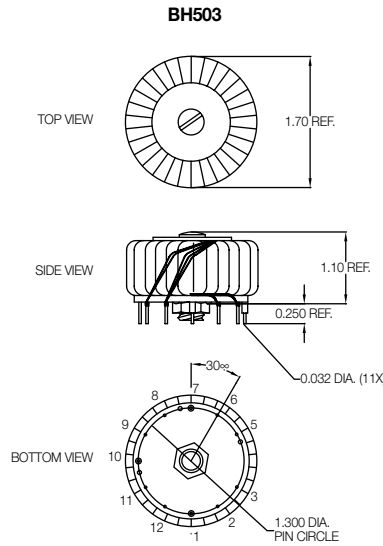
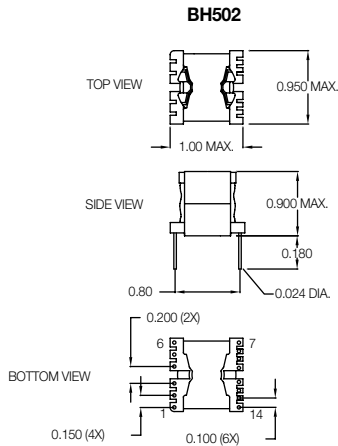
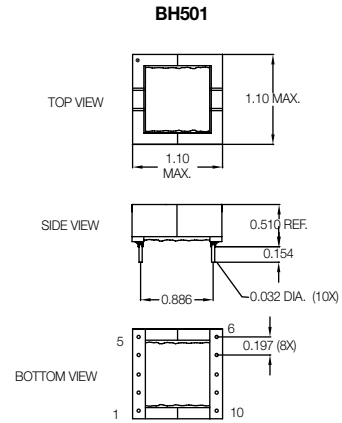
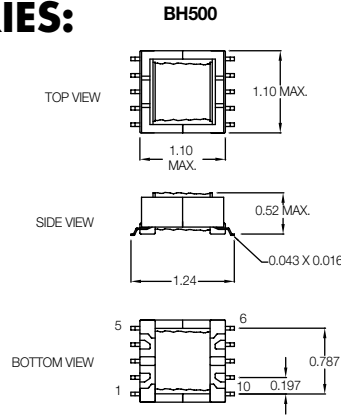

Power Inductors

TOROID INDUCTORS FOR SWITCHING POWER SUPPLIES

- Current range to 50 Amps
- Maximum temperature rise of 40° C
- Wide range of inductances
- Surface mount design and custom package styles available



ELECTRICAL CHARACTERISTICS @ 25° C

BH PART NUMBER	RATED DC CURRENT (AMPS)	MINIMUM INDUCTANCE AT RATED DC (μH)	MINIMUM INDUCTANCE AT ZERO DC (μH)	DC RESISTANCE MAXIMUM (Ω)	MINIMUM ENERGY STORAGE 1/2 L ₁	PACKAGE STYLE	LEAD DIA. INCHES
501-1002	2.5	115	230	.12	3.66	1	0.025
501-1005	4.1	140	280	0.86	1185	2	0.032
L01-1009	6.5	140	280	.070	3000	3	0.040
501-1013	10.0	60	120	0.28	3000	3	0.051
501-1015	20.0	6	12	.006	1200	5	N/A
501-1016	20.0	15	30	.010	3200	6	N/A
501-1017	21.0	30	60	.010	6400	7	N/A
501-1020	50.0	4.5	9	.0016	5875	7	N/A
L01-1089	50.0	3.1	4.23	.0089	5875	7	N/A

Note: Part numbers beginning with "L" are RoHS compliant. Contact BH if you have need for RoHS construction.

PACKAGE STYLE	A (inches) millimeters	B (inches) millimeters	C (inches) millimeters	D (inches) millimeters	E (inches) millimeters	F (inches) millimeters	G (inches) millimeters
1	(1.05)	(0.55)	(.400)	(.800)	(.20)	(1.10)	N/A
	26.67	13.97	10.16	20.32	5.08	27.94	N/A
2	(1.45)	(.80)	(.600)	(.900)	(.20)	(1.40)	N/A
	36.83	20.32	15.24	22.86	5.08	35.56	N/A
3	(2.00)	(.95)	(.700)	(1.20)	(.20)	(1.90)	N/A
	50.80	24.13	17.78	30.48	5.08	48.26	N/A
4	(.755)	(.670)	(000)	(000)	(000)	(.390)	N/A
	19.12	17.02	000	000	000	9.91	N/A
5	(1.45)	(.80)	N/A	(.900)	(.25)	(1.40)	6/32
	36.83	20.32	N/A	22.86	6.35	15.56	6/32
6	(2.00)	(.95)	N/A	(1.20)	(.25)	(1.90)	8/32
	50.80	24.13	N/A	30.48	6.35	48.26	8/32
7	(2.16)	(1.12)	N/A	(1.50)	(.25)	(2.20)	10/32
	54.86	28.45	N/A	38.10	6.35	55.88	10/32

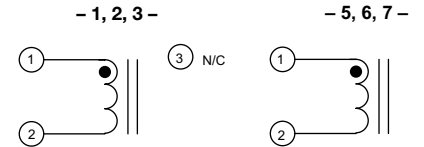

NOTE A: Style 5, 6, and 7 leads cut to 6" - Custom length available upon request.

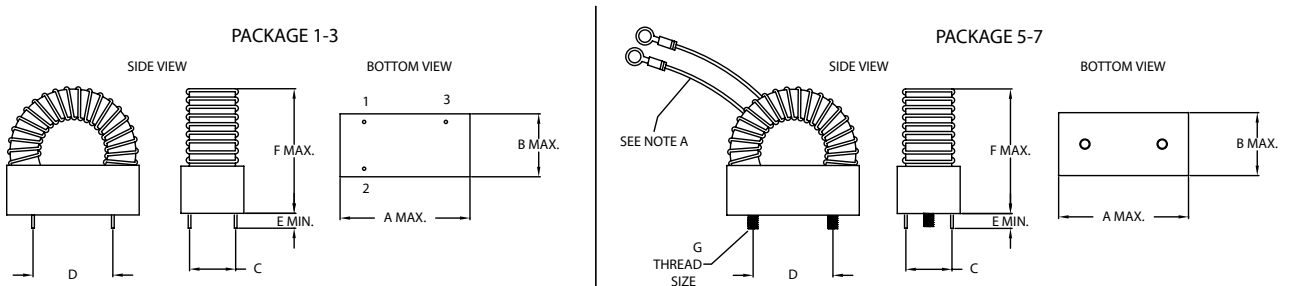

Power and Control Magnetics

CURRENT SENSE TRANSFORMERS

- Current sense for regulation of switch mode power supplies
- Surface mount (SMT) for compact size or through-hole for heavy current
- Isolation to 3000 VAC
- Wide variety of applications from multiple chip vendors
- 10 KHz to 500 KHz frequency of operation
- Use Current Transformer Formula below to determine the BH part number that meets your requirements



ELECTRICAL CHARACTERISTICS @ 25° C

BH PART NUMBER	TURNS RATIO	INDUCTANCE (mH-MIN.)	ET Volt-µSec RATING	DCR PRIMARY OHMS MAX	PACKAGE STYLE	SCHEMATIC	MAX CURRENT RATING Arms	Isolation Voltage
500-2603	1:50	1.40	55	0.006	1	1	6.0	1.5kV RMS
500-2604	1:100	6.0	110	0.006	1	1	6.0	1.5kV RMS
500-2605	1:200	22.0	220	0.006	1	1	6.0	1.5kV RMS
500-2600	1:50	2.15	65	0.004	2	1	8.0	1.5kV RMS
500-2601	1:100	8.75	135	0.004	2	1	8.0	1.5kV RMS
500-2602	1:200	35.0	300	0.004	2	1	8.0	1.5kV RMS
500-2456	1:200	87.0	1400	0.0015	3	2	10.0	3kV RMS

Note: Part numbers beginning with "5" are not RoHS compliant. Contact BH if you have need for RoHS construction.

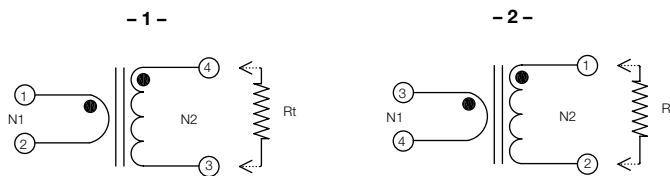
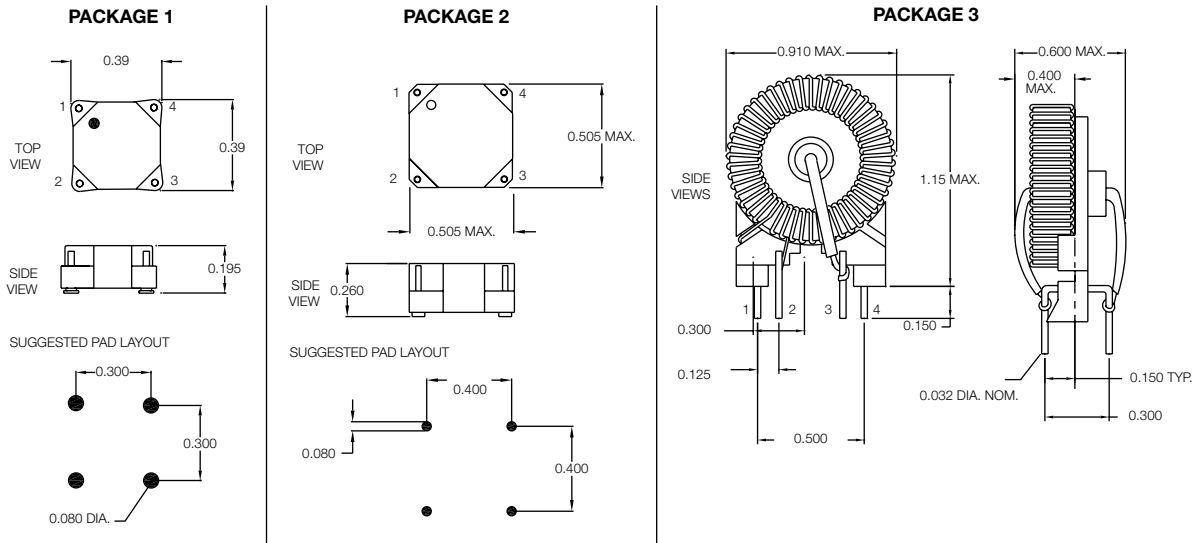

CURRENT TRANSFORMER FORMULA

- $I_{\text{secondary}} = I_{\text{primary}} \div \text{turns ratio}$
- $E \text{ (volts)} = R_t \times I_{\text{secondary}} \text{ (amps)}$
- $T = 1/(2F)$ $F = \text{Frequency in Hz}$
- $E \times T$ must be less than ET Volt uSec Rating
- R termination selected by designer

Power and Control Magnetics

Control Transformers

MOSFET/TRIAC/SCR TRIGGER TRANSFORMERS

- Ideal for use as trigger transformers in Mosfet, SCR and Triac circuits
- High isolation voltages - Hi-pot tested to 2500 VAC
- Fully encapsulated
- Designed for fast rise time applications



ELECTRICAL CHARACTERISTICS @ 25° C

BH PART NUMBER	TURNS RATIO	PRIMARY INDUCTANCE (mH-MIN.)	PRIMARY ET-CONSTANT	LEAKAGE INDUCTANCE (μH)	Ciw (pf MAX.)	DCR PRI (Ω)	DCR SEC (Ω)	DCR SEC (Ω)	SCHEMATIC
L05-5500	1:1	0.25	45	5	20	1	1	N/A	2
505-5501	1:1	1	90	20	30	2	2	N/A	2
505-5502	1:1	5	180	45	30	3	3	N/A	2
505-5503	1:1	20	360	200	50	5	5	N/A	2
505-5504	1:1:1	0.25	45	5	20	1	1	1	1
505-5505	1:1:1	1	90	20	30	2	2	2	1
505-5506	1:1:1	5	180	45	30	3	3	3	1
505-5507	1:1:1	20	360	200	50	5	5	5	1
505-5508	2:1	1	90	40	30	2	1	N/A	2
505-5509	2:1	5	180	60	30	3	2	N/A	2
505-5510	2:1:1	1	90	40	30	2	1	1	1
L05-5511	2:1:1	5	180	60	30	3	2	2	1
505-5512	5:1	20	360	200	50	5	2	N/A	2
505-5513	5:1:1	20	360	200	50	5	2	2	1
505-5570	1:1	0.25	45	5	20	1	1	N/A	3
505-5571	1:1:1	0.25	45	5	20	1	1	1	4
505-5572	1:1	1	90	20	30	2	2	N/A	3
505-5573	1:1:1	1	90	20	30	2	2	2	4
505-5574	1:1	5	180	45	30	3	3	N/A	3
505-5575	1:1:1	5	180	45	30	3	3	3	4
505-5576	1:1	20	360	200	50	6	6	N/A	3
505-5577	1:1:1	20	360	75	50	3	3	3	4
505-5578	2:1	1	90	40	30	2	1	N/A	3
505-5579	2:1:1	1	90	60	30	2	1	1	4
505-5580	2:1	5	180	40	30	3	2	N/A	3
505-5581	2:1:1	5	180	45	30	3	2	2	4
505-5582	2:1	20	360	200	75	5	3	N/A	3
505-5583	2:1:1	20	360	200	75	3	2	2	4
505-5584	5:1	20	360	200	50	5	2	N/A	3
L05-5585	5:1:1	20	360	200	50	5	2	2	4

Note: Part numbers beginning with "L" are RoHS compliant. All others could be made RoHS compliant. Contact BH Electronics.

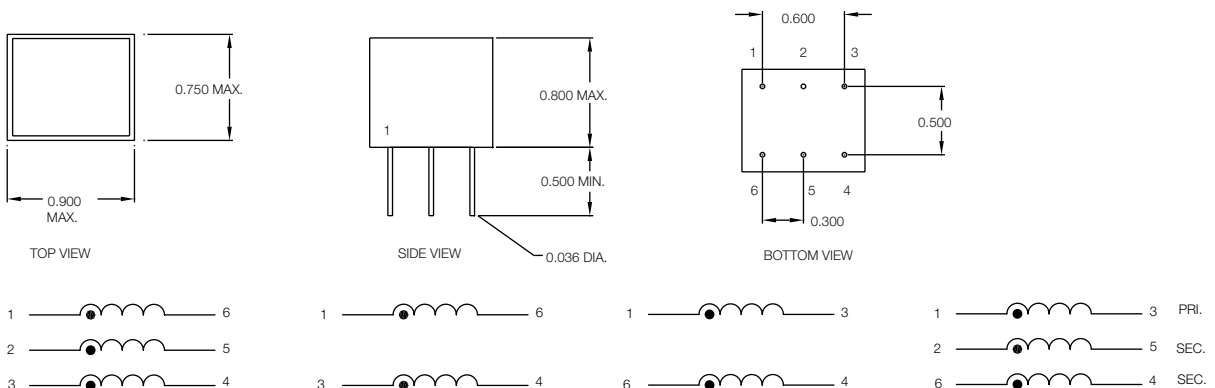

QTR-Pak™ & 8th-Pak™ Common Mode Power Chokes



- Proven, high reliability SMT package design
- 400 VAC isolation voltage
- Matte Sn over Ni over brass pins
- Superior coplanarity
- Superior inspectability
- Feet available to reflow solder heat
- Available in JEDEC trays or tape & reel (L10-400/Reel; L11-1000/Reel)

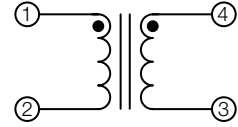

BH PART NUMBER	TYPE	OCL (Nom.)	IMPEDANCE (Typ.; Min.)	FREQUENCY	DCR/WINDING (Typ.)	RATED CURRENT
L11-0103	8th-Pak	150uH	600 Ohms	10 MHz	10 mOhms	3.6 Amps
L11-0105	8th-Pak	20uH	800 Ohms	100 MHz	19 mOhms	3.6 Amps
L10-0100	QTR-Pak	9 uH	600 Ohms	100 MHz	8 mOhms	7.9 Amps
L10-0101	QTR-Pak	41 uH	800 Ohms	10 MHz	16 mOhms	5.6 Amps
L10-0103	QTR-Pak	180 uH	1.1 kOhms	10 MHz	8 mOhms	5.6 Amps
L10-0105	QTR-Pak	435uH	300 Ohms	100 MHz	9 mOhms	5.6 Amps

Electrical specifications at 25° C. Operating temperature range -40°C to +125°C

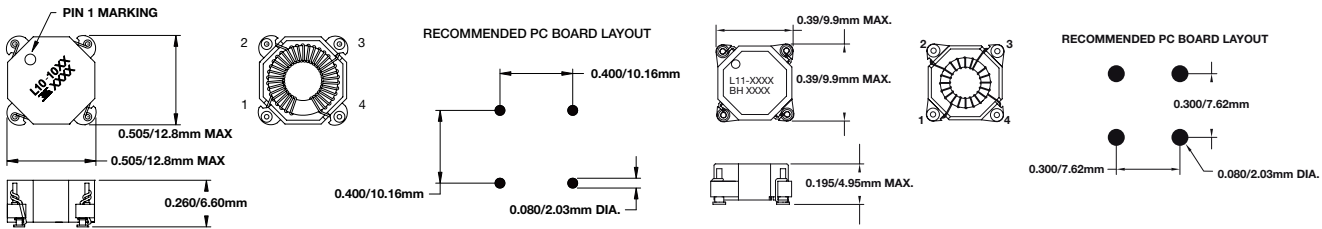

Impedance vs Frequency - BH QTR-Paks (L10-) and 8th-Paks (L11-)

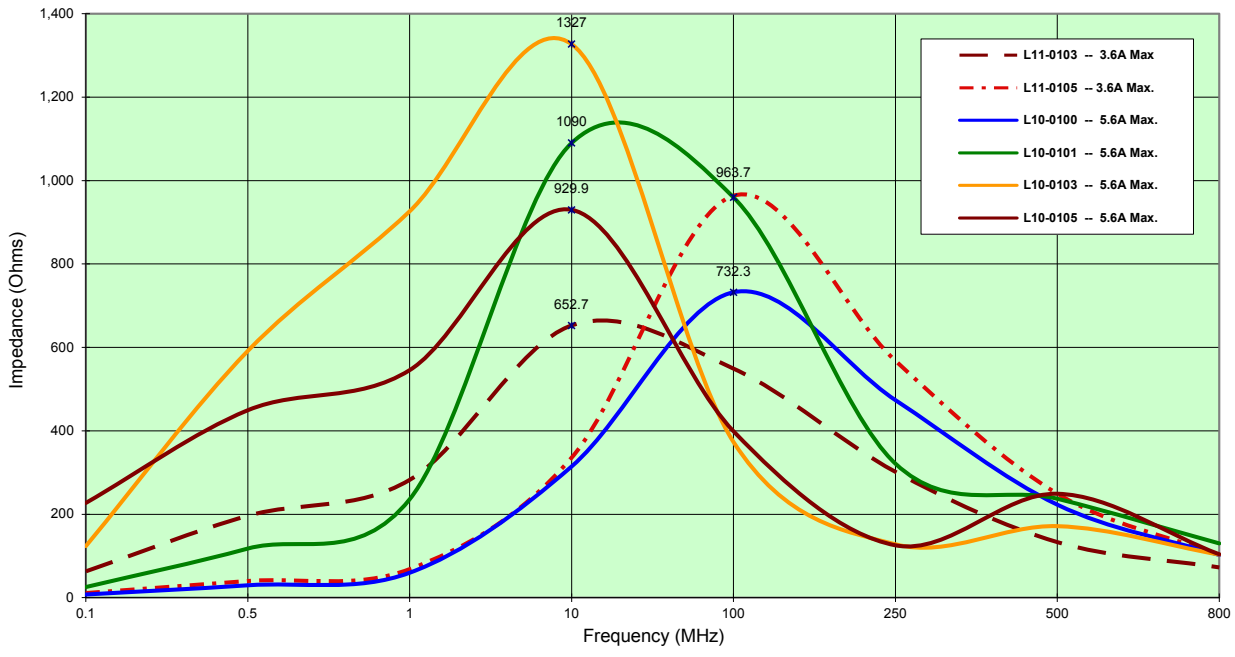

Common Mode Chokes

Telecommunications & Data Network Circuits

- For the rejection of RFI and EMI on unshielded twisted pair (UTP) lines
- 1000 VDC isolation
- Custom designs in a wide variety of packages



ELECTRICAL CHARACTERISTICS @ 25° C

BH PART NUMBER	TURNS RATIO	REFERENCE INDUCTANCE @ 100 KHz	CI MAX. ANY WINDING	DGR MAX	SCHEMATIC	PACKAGE STYLE	DIM "A"	DIM "B"
L00-1164	1:1	33 uH	20pF	0.05	4	4		
500-1165	1:1:1:1	27 uH	30pF	0.05	1	1	0.45	0.35
500-1179	1:1:1:1	53 uH	30pF	0.1	1	1	0.59	0.5
500-1266	1:1	15mH	260pF	2	4	1	0.58	0.5
500-1267	1:1	125 uH	150pF	0.5	4	1	0.58	0.5
500-1291	1:1	53 uH	30pF	0.1	4	1	0.59	0.55
500-1299	1:1	750 uH	15pF	0.3	3	2		
500-1433	1:1	750 uH	15pF	0.3	3	2		
500-1517	1:1:1:1	50 uH	20pF	0.15	1	1	0.42	0.35
500-1532	1:1:1:1	12 uH	10pF	0.1	1	1	0.45	0.36
500-1841	1:1:1:1	8 uH	10pF	0.2	1	3		
500-1910	1:1	85 uH	10pF	0.08	4	4		
500-2063	1:1	64 uH	30pF	0.2	2	5		
501-0752	1:1	12mH	350pF	14	2	5		
L10-0009	1:1	9mH	55pF	1.25	4	5		

Note: Part numbers beginning with "L" are RoHS compliant.

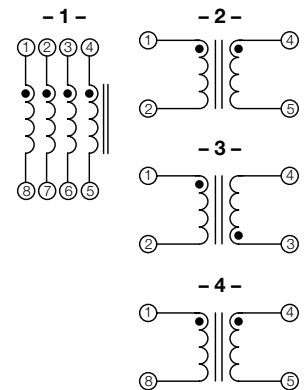
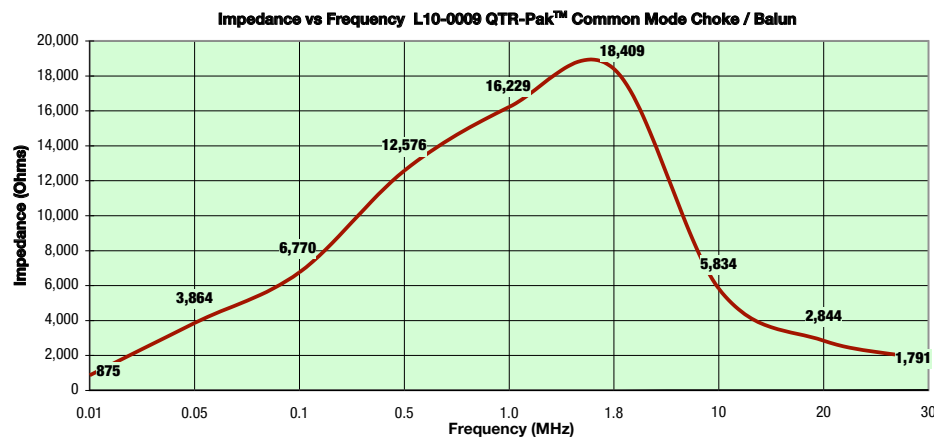
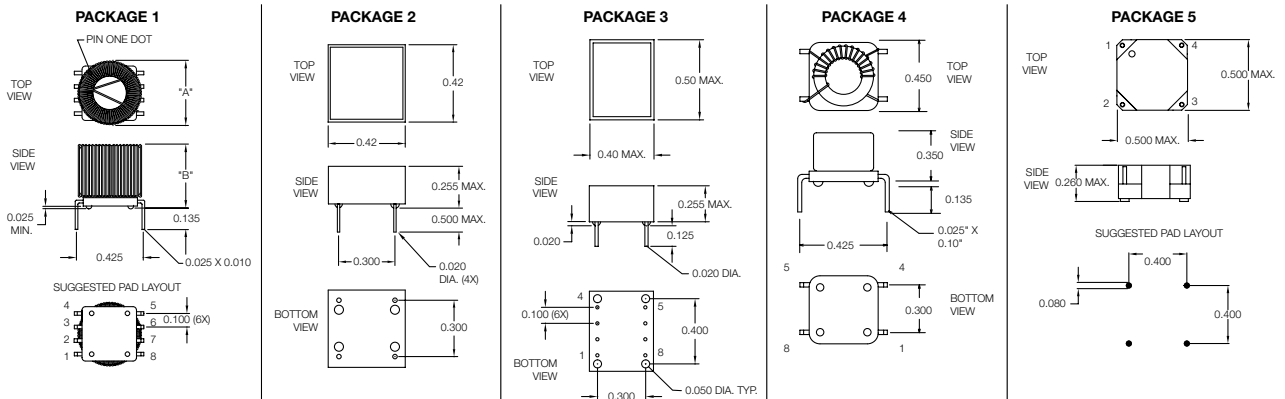

For greater detail see web site

Baseband Video Components

- Wide band transformers and chokes support NTSC, PAL & SECAM based video including 60 Hz synchronization frequency
- Custom versions available
- Several impedances matched
- Reference bhelectronics.com for detailed application notes and drawings



ELECTRICAL CHARACTERISTICS @ 25° C

BH PART NUMBER	IMPEDANCE	APPLICATION
L10-0009	75Ω to 100Ω	Composite Video Common Mode Choke
501-0971	75Ω to 100Ω	Composite Video Common Mode Choke
501-1209	75Ω to 100Ω	S-Video, Component Video
500-2547	Various	Composite Video Balun with Options
500-3118	75Ω to 100Ω	Composite Video Balun Transformer
L00-3094	75Ω to 75Ω	Composite Video Isolation Transformer
L40-0212	75Ω to 100Ω	Composite Video Balun Assembly

Note: Part numbers beginning with "L" are RoHS compliant.

SCHEMATICS

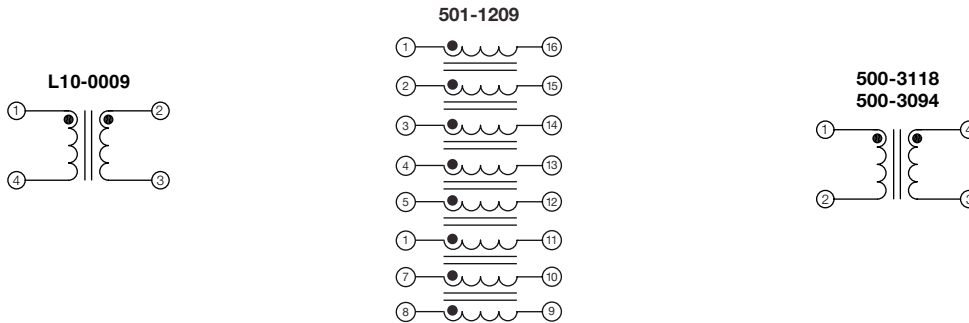

MECHANICALS

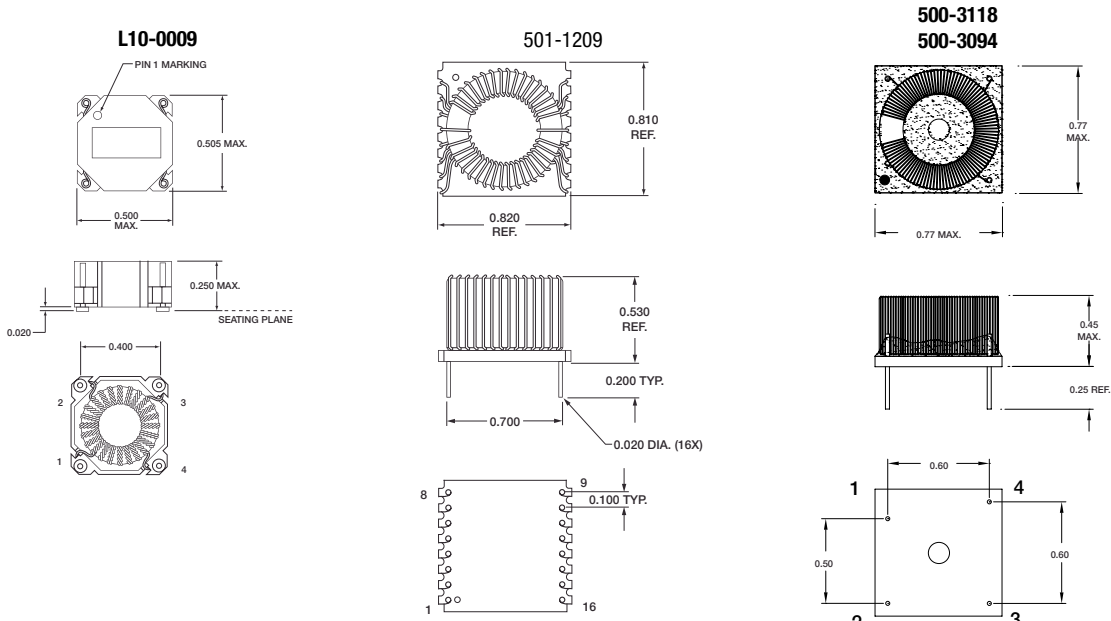

Magnetics for Telecommunications & Data Network Circuits

IMPEDANCE MATCHING AND ISOLATION TRANSFORMERS

- Designed for use in line matching and isolation circuits
- Ideal for use as baluns or as isolation transformers
- Use in popular networks such as Ethernet or 10 Base T and 100 Base T
- Use in proprietary networks based on RS232, RS422 or RS485
- Products are available to support data rates from 9.6Kb/sec. to 250Mb/sec.



ELECTRICAL CHARACTERISTICS @ 25° C

BH PART NUMBER	ET CONSTANT (V SEC. MIN.)	TURNS RATIO	PRIMARY INDUCTANCE	ISOLATION VOLTAGE	SCHEMATIC	PACKAGE STYLE	DIM. "A" MAX.	DIM. "B" MAX.
500-1430	40	1:1:27	2.8mH	500 VDC	6	6	.37	.32
L00-1455	100	1:1	21mH	1500 VRMS	3	1	0.4	0.35
500-1461	1200	1:1	800mH	2200 VRMS	4	1	0.57	0.4
500-1463	000	1:1	140uH	1200 VAC	4	3	0.54	0.31
500-1465	380	1CT: 1CT	193mH	1500 VRMS	2	1	0.45	0.43
500-1438	3	1CT: 1CT	150 H	500 VDC	5	2	N/A	N/A
500-1542	900	1CT: 1CT	430MH	2900VDC	2	1	0.56	0.39
500-1544	90	1: 1CT	2.2mH	1000 VRMS	1	1	0.60	0.35
500-2279	1.5	1: 1 TAPPED	100 uH	2500 VAC	5	4	N/A	N/A
500-2387	14	1:1.22 TAPPED	1.0mH	1500 VAC	6	5	N/A	N/A

Note: Part numbers beginning with "L" are RoHS compliant.

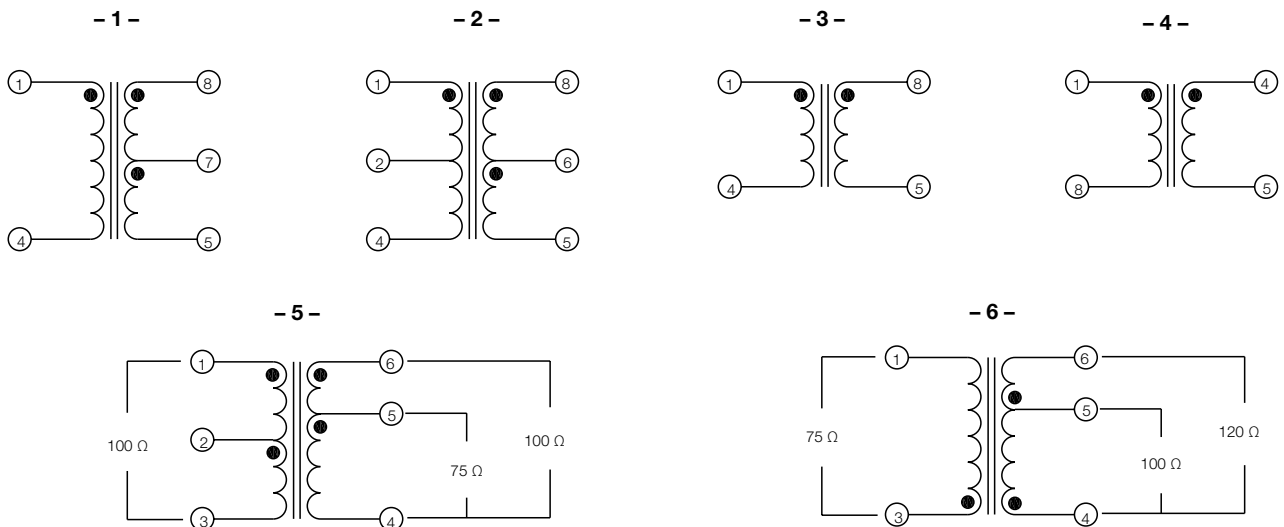

Magnetics for Telecommunications & Data Network Circuits

IMPEDANCE MATCHING AND ISOLATION TRANSFORMERS

(continued)

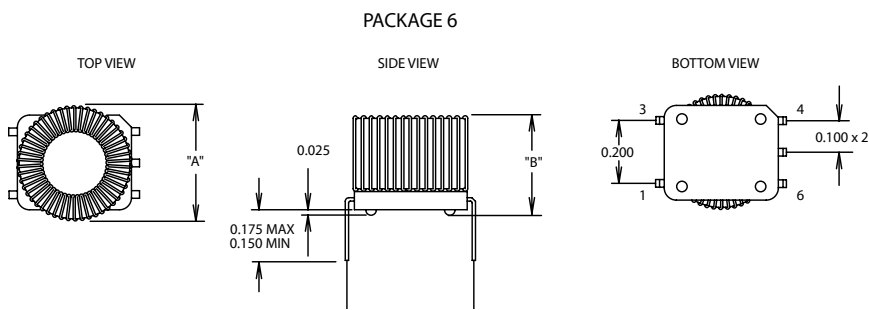
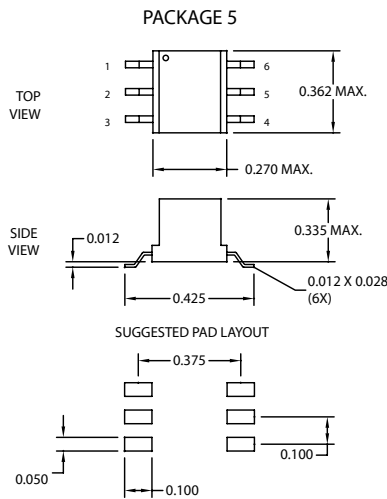
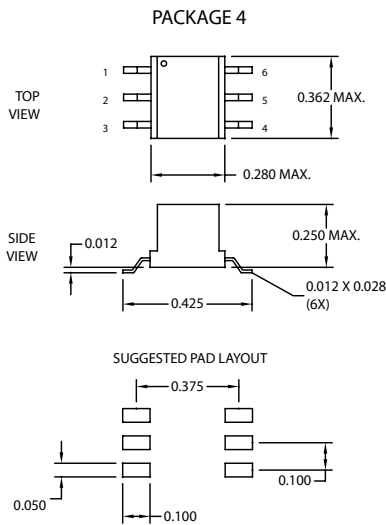
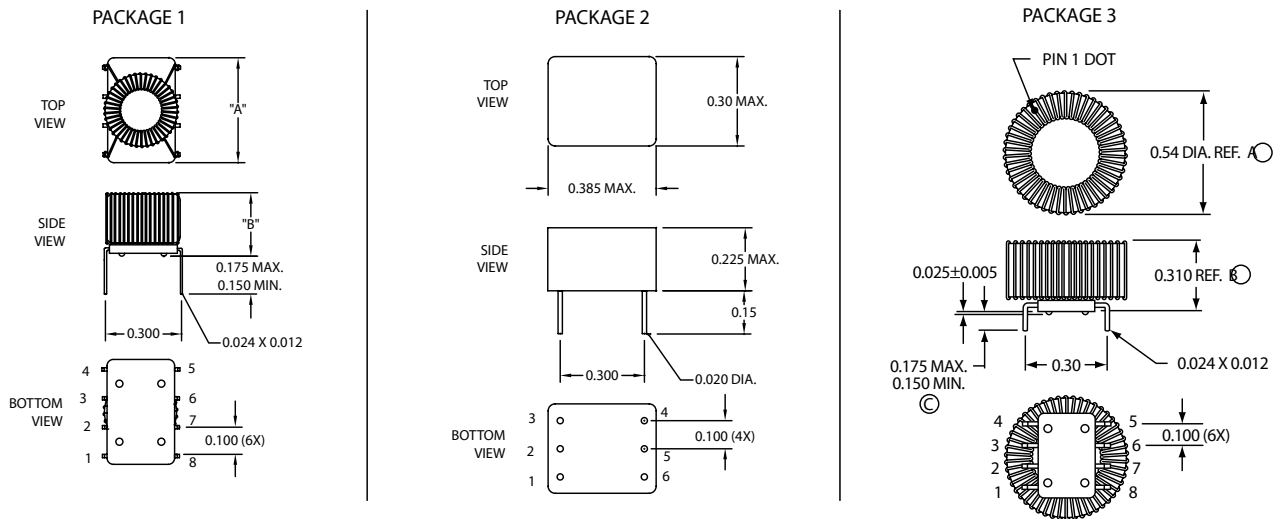

Extreme Magnetics

HIGH CURRENT POWER INDUCTORS

- Ruggedized COTS Inductors
- High Current and High Inductance for SMT Applications
- -40 to 125C operating temperature
- Fully Potted
- Electrical Specifications @ 25C



ELECTRICAL CHARACTERISTICS @ 25° C

BH PART NUMBER	INDUCTANCE (μH)	DC RESISTANCE MAXIMUM (Ω)	Maximum I Peak (A)
501-2020	1.0	0.0025	20.0
501-2021	1.8	0.0034	15.3
501-2022	2.8	0.0054	12.3
501-2023	4.0	0.0080	10.3
501-2024	0.3	0.0018	35.0
501-2025	0.8	0.0025	27.2
501-2026	1.4	0.0034	20.8
501-2027	2.2	0.0054	14.8
501-2028	3.2	0.0080	12.8

Power Magnetics

EXTREME MAGNETICS

Magnetic components designed for use at extreme temperatures and in high vibration applications for use in demanding industrial, military and deep well drilling applications. Most are fully encapsulated and all are rated for use at temperatures between -40°C and +125°C. Custom versions are available upon request. Contact your local BH Electronics representative. The following devices are shown to illustrate BH Electronics' range of capabilities for magnetics that must operate in extreme environments. Contact BH with your specific design requirements.

ELECTRICAL CHARACTERISTICS @ 25° C

BH PART NUMBER	TURNS RATIO	DEVICE TYPE	PRIMARY INDUCTANCE	DCR OHMS	MAXIMUM CURRENT ADC	MIL-STD-202*
500-2506	1:1:1	Pulse Transformer	1mH	2.5	N/A	X
500-2746	1:1	Gate Drive Transformer	1.25mH	0.36	N/A	X
501-0810	N/A	Inductor	30uH	0.055	4.3	X
501-0911	N/A	Inductor	360nH	0.015	2	X
501-0912	N/A	Inductor	840uH	0.022	1	X
501-0913	N/A	Inductor	3.0uH	0.105	0.5	X
501-0977	N/A	Inductor	.45uH	0.003	8.1	X
501-1362	N/A	Inductor	50uH	0.025	70	X

* Thermal Shock: MIL-STD-202, Method 107 but with a max. temp of 125°C.

* Operating temperature range: -46°C to +125°C.

For mechanical details on these parts contact BH Electronics.

Power Magnetics

EXTREME MAGNETICS (CONTINUED)

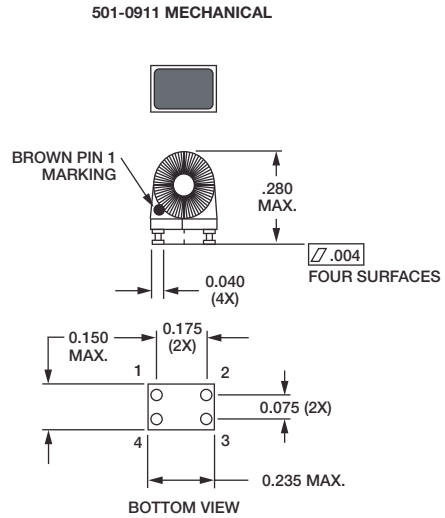
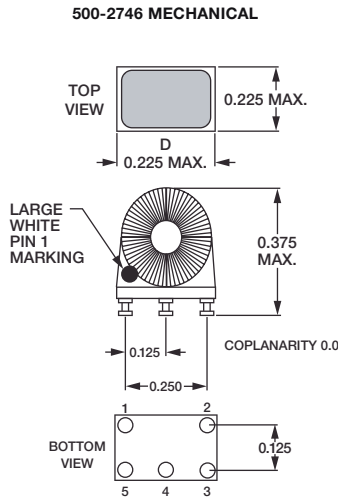
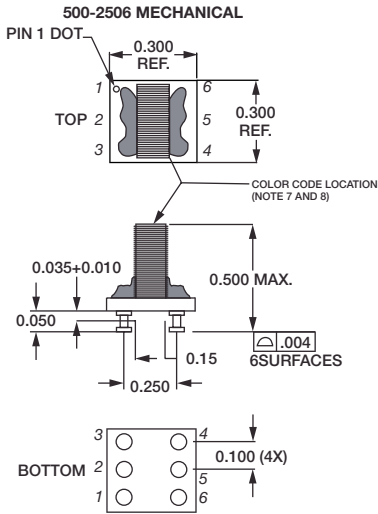

501-0912 MECHANICAL

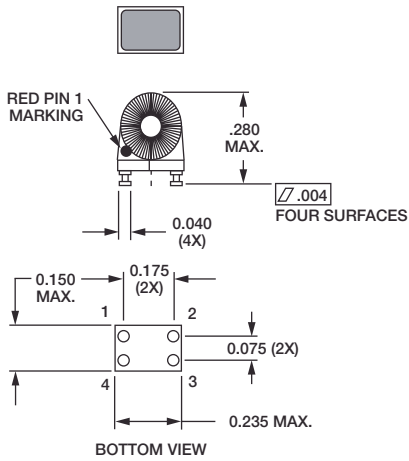

501-0913 MECHANICAL

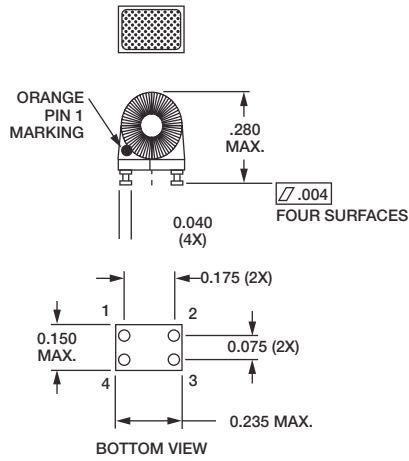

501-0977 MECHANICAL

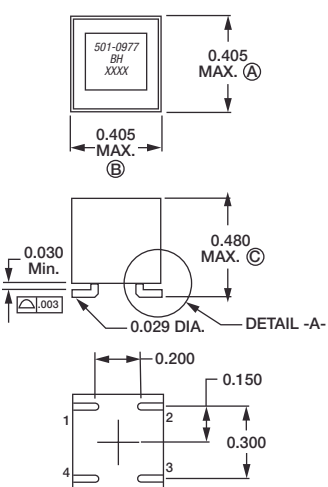

500-2506 SCHEMATIC

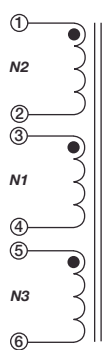

500-2746 SCHEMATIC

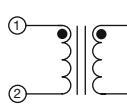

501-0911 SCHEMATIC

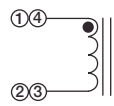

501-0912 SCHEMATIC

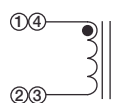

501-0913 SCHEMATIC

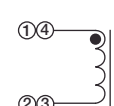

501-0977 SCHEMATIC

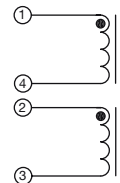

Test Baluns

NETWORK TEST BALUNS



Patents #6,100,772 and #6,486,747

- Convert 50Ω unbalanced to 100Ω balanced signals
- Designed for use in testing network cable connectors and wiring systems
- Rugged brass case construction
- Replaceable test sockets
- Dual SMA connectors
- Termination Resistors available – 100Ω (BH Part #040-0111) and Y (BH Part #040-0112)
- Gold plated connectors

BH PART NUMBER	FREQUENCY RANGE
040-0055	350 MHz Special Order
040-0071	100KHz to 100MHz Special Order
040-0093	Replaced by 040-0092
040-0092	1 MHz to 650 MHz
040-0192	1 MHz to 650 MHz
040-0229	1 MHz to 1.3 GHz
040-0111	100Ω Termination Resistor
040-0112	Y Termination Resistor

See detail drawings at bhelectronics.com.

DSL TEST BALUNS

Patents pending

- Specially tuned and balanced for DSL circuits
- <1dB insertion loss
- Seven impedance ranges available
- Through-hole mounting option available
- Common mode rejection 50dB min (200 Hz to 1.2 MHz)



ELECTRICAL CHARACTERISTICS @ 25° C

BH PART NUMBER	IMPEDANCE	INSERTION LOSS	RETURN LOSS - BI-DIRECTIONAL
040-0080	50:600	1dB max (200 Hz - 1.2 MHz)	17.5 dB min (200 Hz - 500Hz)
	50:600	1dB max (200 Hz - 1.2 MHz)	20 dB min (500 Hz - 1.0 MHz)
	50:600	1dB max (200 Hz - 1.2 MHz)	17.5 dB min (1.0 MHz - 1.2 MHz)
040-0081	50:125	1dB max (200 Hz - 1.2 MHz)	17.5 dB min (200 Hz - 500 Hz)
	50:125	1dB max (200 Hz - 1.2 MHz)	20 dB min (500 Hz - 1.2 MHz)
040-0082	75:600	1dB max (200 Hz - 1.2 MHz)	17.5 dB min (200 Hz - 500 Hz)
	75:600	1dB max (200 Hz - 1.2 MHz)	20 dB min (500 Hz - 1.0 MHz)
040-0083	50:900	1dB max (200 Hz - 1.0 MHz)	17.5 dB min (200Hz - 500 Hz)
	50:900	1dB max (200 Hz - 1.0 MHz)	20 dB min (500 Hz - 750 KHz)
	50:900	1dB max (200 Hz - 1.0 MHz)	17.5 dB min (750 KHz - 1.0 MHz)
040-0084	50:135	1dB max (200 Hz - 1.2 MHz)	17.5 dB min (200Hz - 500 Hz)
	50:135	1dB max (200 Hz - 1.2 MHz)	20dB min (500 Hz - 1.2 MHz)
040-0085	50:85	1dB max (200 Hz - 1.2 MHz)	17.5 dB min (200 Hz - 500 Hz)
	50:85	1dB max (200 Hz - 1.2 MHz)	20 dB min (500 Hz - 1.2 MHz)
040-0088	50:100	1dB max (200 Hz - 1.2 MHz)	17.5 Hz min (200 Hz - 500 Hz)
	50:100	1dB max (200 Hz - 1.2 MHz)	20 dB min (500 Hz - 1.2 MHz)
040-0095 Through-Hole	50:100	1dB max (200 Hz - 1.2 MHz)	17.5 dB (200 Hz - 500 Hz)
	50:100	1dB max (200 Hz - 1.2 MHz)	20 dB min (500 Hz - 1.2 MHz)
040-0097	50:100	.75 dB max (25 KHz - 30 MHz)	20 dB min (25 KHz - 30 MHz)

Test set-ups, mechanicals and schematics are available upon request via our website.

ISO 9001 Certified Quality System

12219 Wood Lake Drive, Burnsville MN 55337
Phone: (952) 894-9590 · Fax: (952) 894-9380

Custom Magnetics
Magnetic Assemblies
Standard Magnetics
Video Components
Test Baluns

Visit our website at
www.bhelectronics.com



Represented by:



BH® **BH Electronics**
INNOVATIVE MINDS...EXCEPTIONAL QUALITY

BHC-15